



## PRODUCT DATA

DIMENSIONS, TECHNICAL INFORMATION AND PERFORMANCE SPECIFICATION

# multibase 2042i



## Table of contents

Explanation of symbols.....	2	Loading schedule.....	7
Parking positions.....	2	Access incline.....	8
Dimensions and tolerances.....	2	Clearance for installations.....	8
Overview of building configuration.....	3	Electrical installation.....	9
Vehicle data.....	3	Technical information.....	10
Overview of system types and ceiling heights.....	4	Performance specification.....	11
Width dimensions.....	5	Services to be provided by the customer.....	12
Width dimension with door.....	5	Subject to technical changes.....	12
Width dimension without door.....	6		

## Explanation of symbols



Platforms accessible tilted.



max. load per parking space in kg.  
Upweighting over 2000 kg possible with surcharge (see "Vehicle data", page 3).



The systems provided are consistent with DIN EN 14010 and the EC Machinery Directive 2006/42/EC.

## Parking positions

### Lower parking space

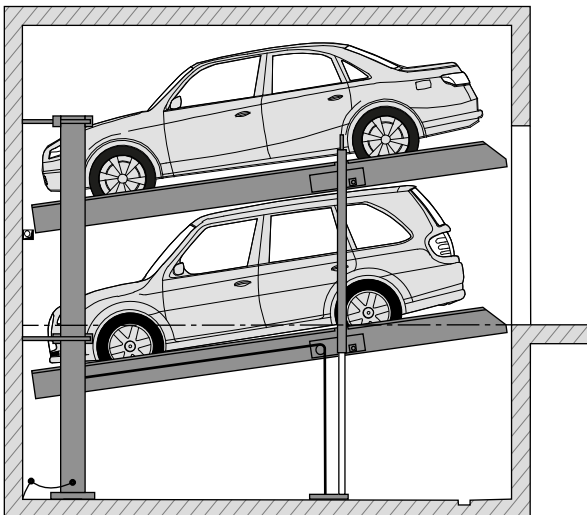

The lower vehicle can park in or leave the parking space.  
Gradient of the lower platform approx.  $7.5^\circ = 13\%$

### Upper parking space

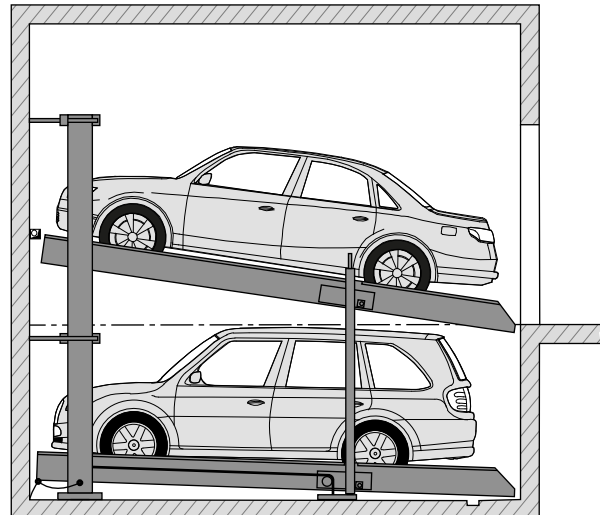

The upper vehicle can park in or leave the parking space.  
Gradient of the upper platform approx.  $7.5^\circ = 13\%$

## Dimensions and tolerances



All dimensions and minimum final dimensions.  
Tolerance for dimensions  $+3/0$ . Dimensions in cm.  
In order to adhere to the minimum final dimensions, the tolerances in accordance with the German Construction Tendering and Contract Regulations [VOB], Part C (DIN 18330 and 18331) and DIN 18202 must also be taken into account.

## Overview of building configuration

### Building configuration without door

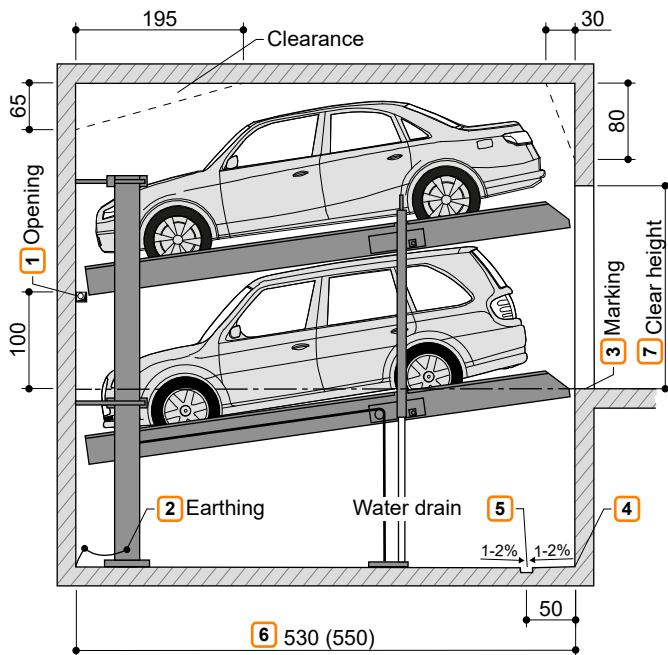

### Building configuration with door

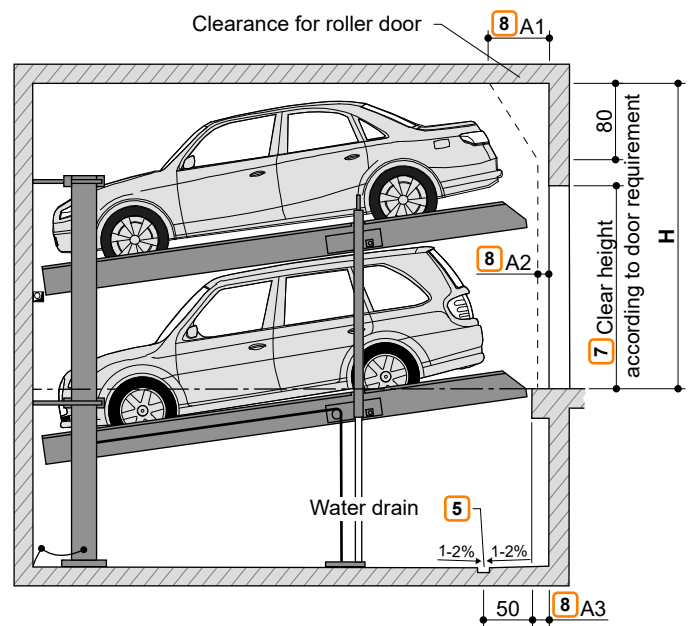

- 1 If there are dividing walls: Wall opening 10 x 10 cm.
- 2 Equipotential bonding from the foundation earth connection to the system (on site).
- 3 In accordance with DIN EN 14010, the customer must provide 10 cm wide, yellow/black marking in accordance with DIN ISO 3864 in the access area along the edge of the pit to identify the hazard area. (see "Loading schedule", page 7).
- 4 No fillets/haunches are permitted at the transition from the pit floor to the walls. If fillets/haunches are required, the systems must be narrower or the pits wider.

- 5 Slope with water collection channel (see "Drainage", page 12).
- 6 ■ 530 cm for vehicles up to 5.0 m long  
■ 550 cm for vehicles up to 5.2 m long  
Shorter versions are possible on request - observe local regulations on parking space lengths.  
We recommend a pit length of 550 cm. for comfortable use of your parking space and increasingly longer vehicles.
- 7 Clear height in accordance with local regulations. Maximum vehicle height + 10 cm.
- 8 Dimensions A1, A2 and A3 must be agreed on-site with the door manufacturer.

## Vehicle data

### Version

SP (single platform) = 2 vehicles  
DP (double platform) = 4 vehicles

### Parking options

Series vehicles:  
saloon, estate, SUV, van in accordance with clearance gauge and maximum parking space load.

	SP			DP	
<b>Weight</b>	2000 kg	2600 kg	3000 kg	2000 kg	2600 kg
<b>Wheel load</b>	500 kg	650 kg	750 kg	500 kg	650 kg

Vehicle width 190 cm with platform width 230 cm.  
Correspondingly wider vehicles can be parked with wider platforms.

- 1 Vehicle height (see "Overview of system types and ceiling heights", page 4)
- 2 Vehicle length (see "Overview of building configuration", page 3)

### Saloon clearance gauge

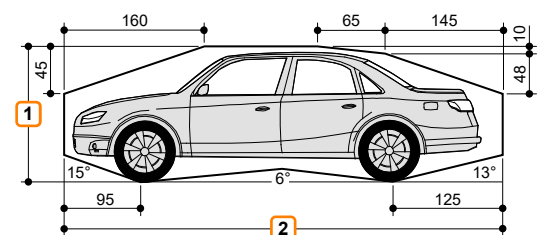

### Estate clearance gauge

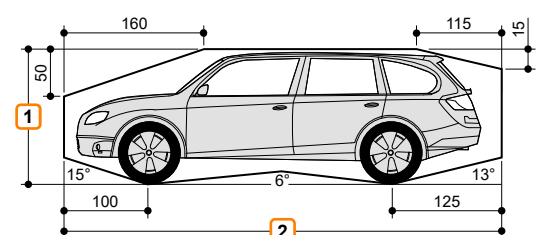

## Overview of system types and ceiling heights

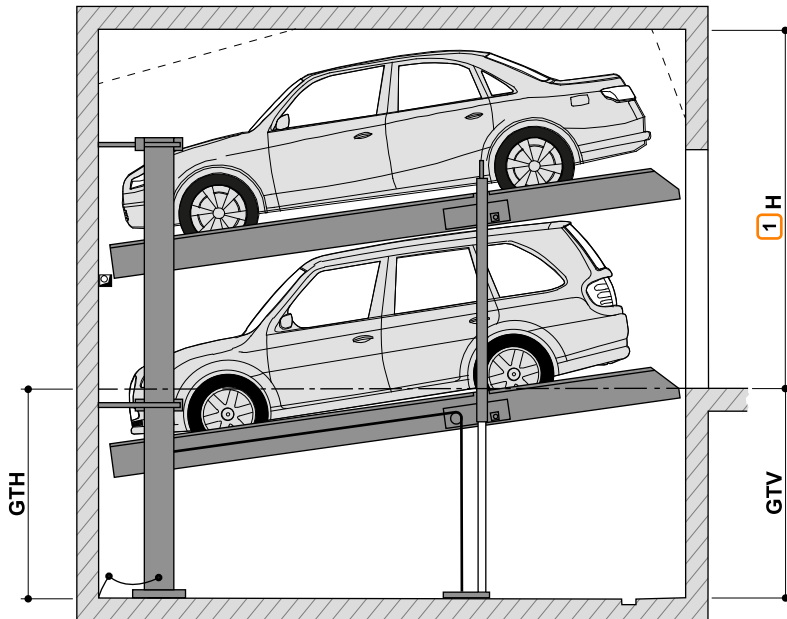

H: Ceiling height  
GTV: Pit depth, front  
GTH: Pit depth, rear

1 If the ceiling is higher, correspondingly higher vehicles can be parked on the top.

Type	GTH	GTV	Vehicle height, lower	Vehicle height, saloon, upper																	
				145	150	155	160	165	170	175	180	185	190	195	200	205	210	215			
				Vehicle height, estate, upper																	
				145	150	155	160	165	170	175	180	185	190	195	200	205	210	215	220		
2042i-145	145	150	145	280	285	290	295	300	305	310	315	320	325	330	335	340	345	350	355	360	365
2042i-150	150	155	150	285	290	295	300	305	310	315	320	325	330	335	340	345	350	355	360	365	370
2042i-155	155	160	155	290	295	300	305	310	315	320	325	330	335	340	345	350	355	360	365	370	375
2042i-160	160	165	160	295	300	305	310	315	320	325	330	335	340	345	350	355	360	365	370	375	380
2042i-165	165	170	165	300	305	310	315	320	325	330	335	340	345	350	355	360	365	370	375	380	385
2042i-170	170	175	170	305	310	315	320	325	330	335	340	345	350	355	360	365	370	375	380	385	390
2042i-175	175	180	175	310	315	320	325	330	335	340	345	350	355	360	365	370	375	380	385	390	395
2042i-180	180	185	180	315	320	325	330	335	340	345	350	355	360	365	370	375	380	385	390	395	400
2042i-185	185	190	185	320	325	330	335	340	345	350	355	360	365	370	375	380	385	390	395	400	405
2042i-190	190	195	190	325	330	335	340	345	350	355	360	365	370	375	380	385	390	395	400	405	410
2042i-195	195	200	195	330	335	340	345	350	355	360	365	370	375	380	385	390	395	400	405	410	415
2042i-200	200	205	200	335	340	345	350	355	360	365	370	375	380	385	390	395	400	405	410	415	420
2042i-205	205	210	205	340	345	350	355	360	365	370	375	380	385	390	395	400	405	410	415	420	425
2042i-210	210	215	210	345	350	355	360	365	370	375	380	385	390	395	400	405	410	415	420	425	430
2042i-215	215	220	215	350	355	360	365	370	375	380	385	390	395	400	405	410	415	420	425	430	435

H - Ceiling height



Width dimension without door

	Single platform - SP	Double platform - DP	Example combination			
Dividing walls						
Support in the pit						
Support outside of the pit						
	Clear platform width	Dividing walls	Support in the pit		Support outside of the pit	
		B1	B2	B3	B4	B5
SP	230	260	255	245	250	240
	240	270	265	255	260	250
	250	280	275	265	270	260
	260	290	285	275	280	270
	270	300	295	285	290	280
DP	460	490	485	475	480	470
	470	500	495	485	490	480
	480	510	505	495	500	490
	490	520	515	505	510	500
	500	530	525	515	520	510
	510	540	535	525	530	520
	520	550	545	535	540	530
	530	560	555	545	550	540
540	570	565	555	560	550	
Combination	230 + 460	750	745	735	740	730
	240 + 470	770	765	755	760	750
	250 + 480	790	785	775	780	770
	250 + 500	810	805	795	800	790
	270 + 500	830	825	815	820	810
	270 + 510	840	835	825	830	820
	270 + 520	850	845	835	840	830
	270 + 530	860	855	845	850	840
270 + 540	870	865	855	860	850	

## Loading schedule



The systems are dowelled into the ground. The depth of the boreholes in the floor plate is approximately 15 cm, and approximately 12 cm in the walls.

The floor plate and walls below entrance level must be from concrete (concrete quality min. C20/25).

The dimensions for the bearing points have been rounded. If the precise figures are required, please consult KLAUS Multiparking.

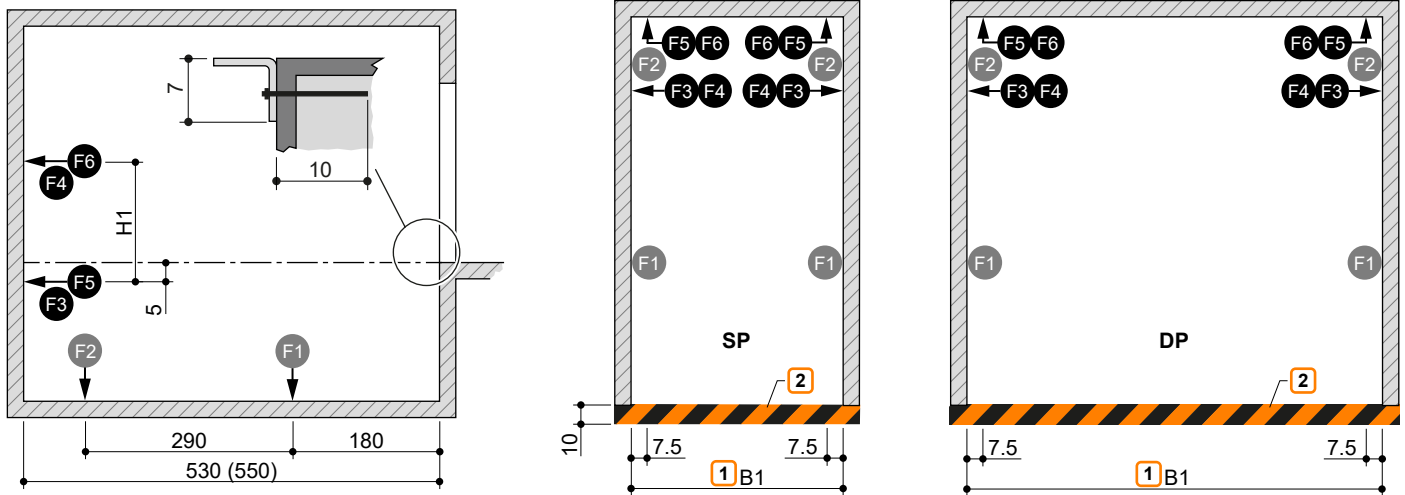

1 Width dimension B1 (see "Width dimension without door", page 6)

2 Marking in accordance with DIN ISO 3864 (illustration colour not consistent with DIN ISO 3864)

Parking space load	F1	F2	F3	F4	F5	F6	Type	H1
SP	2000 kg + 33.2 kN - 5.5 kN	+ 12.5 kN	± 1.3 kN	± 0.7 kN	+ 4.4 kN	- 2.5 kN	2042i-145	125
							2042i-150	130
							2042i-155	135
SP	2600 kg + 40.7 kN - 6.8 kN	+ 15.1 kN	± 1.6 kN	± 0.9 kN	+ 5.5 kN	- 3.1 kN	2042i-160	140
							2042i-165	145
							2042i-170	150
SP	3000 kg + 45.7 kN - 7.6 kN	+ 16.9 kN	± 1.9 kN	± 1.0 kN	+ 6.3 kN	- 3.5 kN	2042i-175	155
							2042i-180	160
							2042i-185	165
DP	2000 kg + 60.8 kN - 9.4 kN	+ 20.6 kN	± 2.4 kN	± 3.1 kN	+ 6.0 kN	- 4.4 kN	2042i-190	170
							2042i-195	175
							2042i-200	180
DP	2600 kg + 73.9 kN - 11.5 kN	+ 25.2 kN	± 3.1 kN	± 3.9 kN	+ 7.4 kN	- 5.4 kN	2042i-205	185
							2042i-210	190
							2042i-215	195

## Access incline



The maximum access inclines specified in the symbol sketch must not be exceeded. Improper configuration can lead to extreme difficulty accessing the system, for which KLAUS Multiparking cannot be held liable. Where above-ground garages are on a slope, provision of a drainage gutter in the access is recommended.

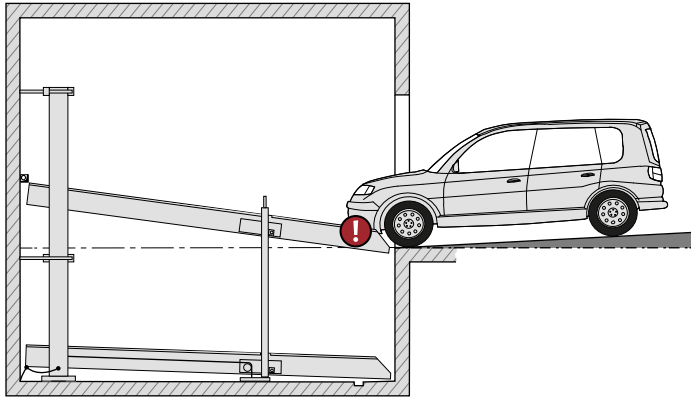

max. 10% slope

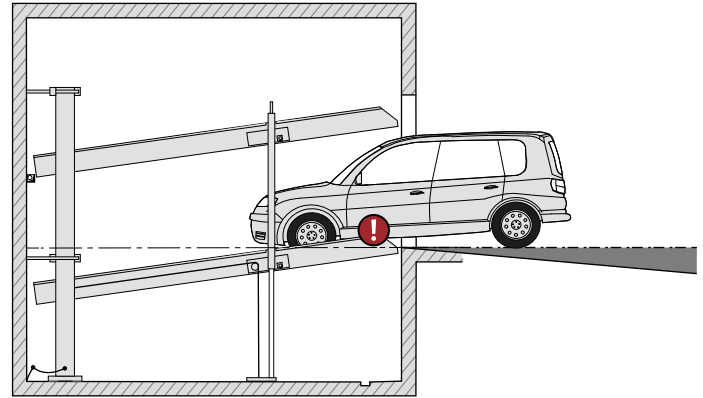

max. 2% gradient

## Clearance for installations



These clearances apply to vehicles parked forwards only, with exit on the left. The clearances must be adjusted for vehicles with exit on the right or parked in reverse.

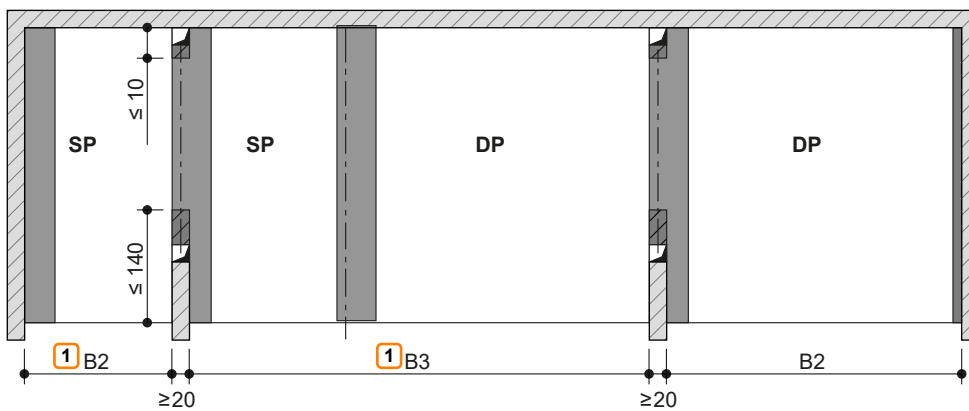
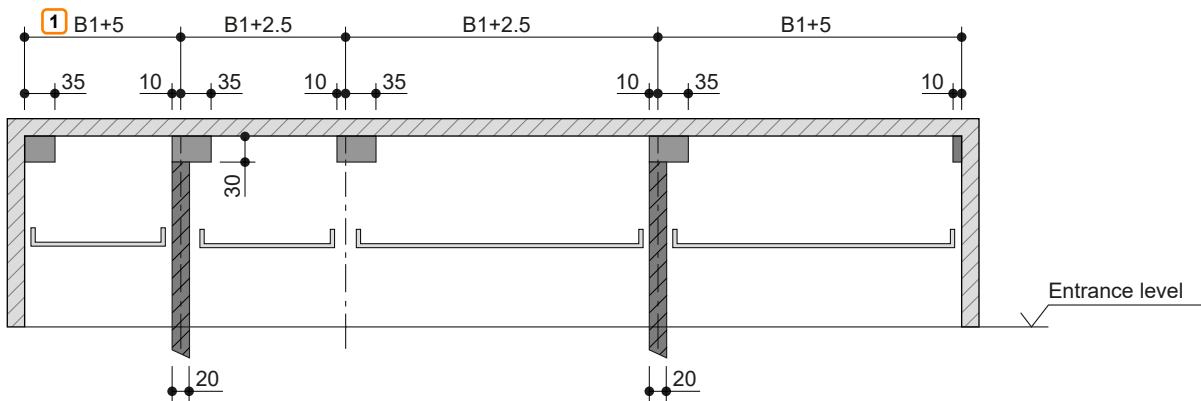

1 Dimensions B1, B2 and B3 (see "Width dimension without door", page 6)

- Clearance for lengthways cable routing
- Clearance for vertical pipes, air ducts, etc.

## Electrical installation

### Electrical installation diagram

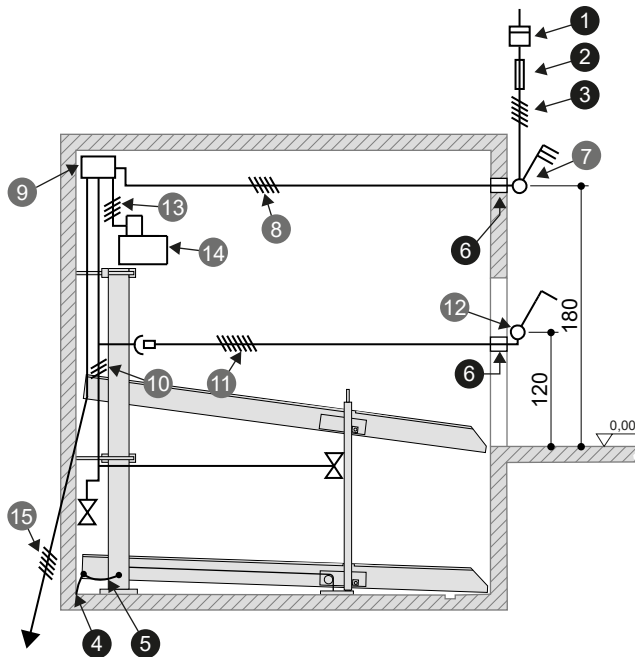

### On-site facilities for operating element

#### Surface-mounted operating element

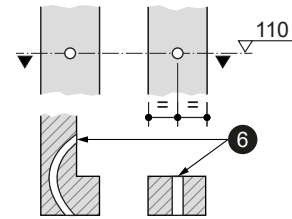

#### Flush-mounted operating element (standard)

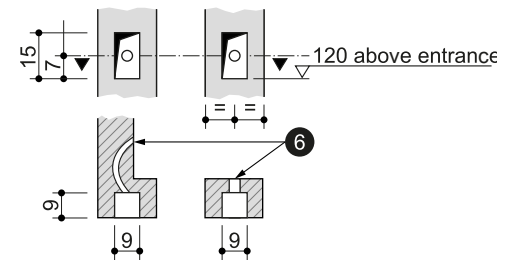

### Electrical specifications (services to be provided by the customer)

No.	Quantity	Designation	Position	Frequency
1	1	Power meter	in the supply cable	
2	1	Pre-fuse: 3x safety fuse 16 A (slow-blow) or Circuit breaker 3x 16 A (trip characteristic K or C)	in the supply cable	1x per 3.0 kW unit
		3x safety fuse 20 A (slow-blow) or Circuit breaker 3x 20 A (trip characteristic K or C)	in the supply cable	1x per 5.2 kW unit
3	1	Supply cable 5 x 2.5 mm <sup>2</sup> (3 PH+N+PE) with marked wires and protective earth	to master switch	1x per 3.0 kW unit
		Supply cable 5 x 4.0 mm <sup>2</sup> (3 PH+N+PE) with marked wires and protective earth	to master switch	1x per 5.2 kW unit
4	every 10 m	Foundation earth connection	Corner of pit floor	
5	1	Equipotential bonding in accordance with DIN EN 60204 from foundation earth connection to system		1x per system
6	2	Empty pipe EN 25 (M25)		

### Electrical specifications (KLAUS Multiparking scope of supply)

No.	Designation
7	Lockable master switch
8	Supply cable 5 x 2.5 mm <sup>2</sup> (3 PH+N+PE) with marked wires and protective earth
	Supply cable 5 x 4.0 mm <sup>2</sup> (3 PH+N+PE) with marked wires and protective earth
9	Unit switch cabinet
10	Multiparker cable harness
11	Connecting cable (operating element)
12	Operating element
13	Control cable 4 x 2.5 mm <sup>2</sup> with marked wires and protective earth
14	Hydraulic unit 3.0 kW/5.2 kW, three-phase current 230/400 V / 50 Hz <span style="border: 1px solid black; padding: 0 2px;">1</span>
15	Connecting cable to next system

1 5.2 kW unit for 2042i 2600 kg double platform only

## Technical information

### Usage area

The system is suitable for a fixed group of users as standard. Where users change - in the upper parking spaces only - (e.g. short-term parking in office buildings or hotels), structural modifications to the Multiparking system are required. Please request a consultation if required.

### Units

Low-noise, bearing-mounted hydraulic units are installed on rubber-metal blocks. Consequently, we recommend separating the garage body from the residential building.

### Ambient conditions

Ambient conditions for the areas around Multiparking systems:  
Temperature range -20 to +40° C. Relative humidity 50 % for a maximum outside temperature of +40° C.  
If ascent/descent times are specified, these relate to an ambient temperature of +10° C and with the system positioned immediately adjacent to the hydraulic unit. These times are increased at lower temperatures or with longer hydraulic lines.

### Building application documents

Multiparking systems generally require approval. Please observe local regulations and stipulations.

### Care

To prevent corrosion damage, please observe our special cleaning and care instructions and ensure that your garage is well ventilated.

### Corrosion protection

In accordance with the 'Corrosion protection information' supplement.

### Railings

If the permissible fall opening is exceeded, railings must be installed on the systems. If there are roadways immediately adjacent to or behind the systems, the customer must provide barriers in accordance with DIN EN ISO 13857. This also applies during the construction stage.

### Noise protection

#### Standard noise protection:

In accordance with DIN 4109-1 Noise protection in high-rise - Section 9: Maximum sound pressure level in living and sleeping areas 30 dB (A). User noise is not subject to the requirements.

The following dimensions are required for adherence to this value:

- Noise protection package in accordance with quote/order (KLAUS Multiparking)
- Sound insulation dimension of the building structure of min. R'w = 57 dB (service to be provided by the customer)

#### Increased sound protection (special agreement):

In accordance with DIN 4109-5 Increased noise protection in high-rise - Section 8:

Maximum sound pressure level in living and sleeping areas 25 dB (A). User noise is not subject to the requirements.

The following dimensions are required for adherence to this value:

- Noise protection package in accordance with quote/order (KLAUS Multiparking)
- Sound insulation dimension of the building structure of min. R'w = 62 dB (service to be provided by the customer)

#### Note:

User noise is noise that can be influenced individually by the user of our Multiparking systems. This includes, e.g., accessing the platform, the slamming of vehicle doors, engine and brake noise.

## Performance specification

### Description

Multiparking system for independent parking of 2 vehicles (single platform - SP), 2x 2 vehicles (double platform - DP) one on top of the other.

Dimensions in accordance with the underlying pit, width and height dimensions.

Access to upper parking spaces inclined (approx. 7.5° gradient).

Access to lower parking spaces inclined (approx. 7.5° gradient).

Special configuration of the lift and support structure prevents hindrance to door opening.

Vehicle positioning in any parking space by positioning aid mounted on one side (to be adjusted in accordance with the operating instructions).

Control via an operating element with automatic reset by means of simultaneous key.

Operating element usually installed in front of the support or on the outside of the door reveal.

Concise instructions at each operating point.

Special dimensions must be observed in buildings with door.

### Multiparking system comprising:

- 2 columns (secured to the floor)
- 2 sliders (with sliding guides secured to the columns)
- 2 platforms
- 1 electrical/hydraulic synchronisation system (for synchronised operation of the hydraulic cylinders when lifting and lowering)
- 2 hydraulic cylinders
- 2 rigid supports (platform connection)
- 2 chains and chain diversion wheels
- Dowels, screws, connectors, bolts, etc.
- The platforms are continuously accessible.

### Platforms comprising:

- Platform profiles
- Adjustable positioning aid
- Chamfered ramps
- Side beams
- Centre beam (DP only)
- Crossbeams (DP long and short crossbeams)
- Railings (on the upper and lower platform - if required)
- Screws, nuts, washers, spacers, etc.

### Hydraulic system comprising:

- Hydraulic cylinders
- Magnetic valves
- Hydraulic lines
- Bolted connections
- High-pressure hoses
- Attachments

### Electrical system comprising:

- Operating element (emergency-stop, key, 1 simultaneous key per parking space)
- Control device with cable harness and sensors

### Hydraulic unit comprising:

- Hydraulic unit (low-noise, fitted to bracket and bearing mounted on rubber-metal block)
- Hydraulic oil tank
- Oil filling
- Internal gear pump
- Pump holder
- Coupling
- Three-phase motor
- Noise protection, motor protection switch and control fuse
- Test pressure gauge
- Pressure relief valve
- Hydraulic hoses (to attenuate noise transmission to the hydraulic pipes)

## Services to be provided by the customer

### Barriers

Barriers that may be required in accordance with DIN EN ISO 13857 to secure the pits where there are roadways immediately in front of, adjacent to or behind the systems. This also applies during the construction stage. Railings on the systems, where required, are included as standard.

### Parking space numbering

Parking space numbering, if required.

### Building services systems

Any lighting, ventilation, fire-extinguishing and fire-alarm systems that may be required, plus clarification and compliance with corresponding official documentation.

### Lighting

The customer must observe local regulations pertaining to the illumination of parking spaces and roadways. In accordance with DIN EN 12464-1 'Light and lighting - Lighting of work places', an illumination level of min. 200 lx is recommended for the parking spaces and operating area of the system.

### Drainage

Functional drainage of the pit must be provided by means of, for example, a water collection channel towards the front that is connected to the sewer system or a pump sump. The channel may contain a lateral slope, but not in the other pit areas (lengthways slope is already provided by the building dimensions). In the interests of environmental protection, we recommend coating the pit floor. Oil and/or fuel separators should be installed in accordance with local regulations.

### Strip foundations

Due to structural conditions, the customer must erect an accessible platform when constructing strip foundations, level with the upper edge of the strip foundation.

### Warning marking

In accordance with DIN EN 14010, the customer must provide 10 cm wide, yellow/black marking in accordance with DIN ISO 3864 in the access area along the edge of the pit to identify the hazard area.

### Wall openings

Any wall openings that may be required should be in accordance with the sectional drawings (see "Overview of building configuration", page 3).

### Supply cable to master switch - foundation earth

The customer must lay the supply cable to the master switch during assembly. Functional capability can be checked by our engineers on site, in conjunction with the electronics engineer. If this is not possible during assembly for reasons attributable to the customer, the customer must commission an electronics engineer.

The customer must earth the steel structure with a foundation earth connection (earthing distance max. 10 m) and equipotential bonding in accordance with DIN EN 60204.

### Operating element

Empty conduits and recesses for the operating element (see "Electrical installation", page 9). Consultation with KLAUS Multiparking is required when using folding doors.

## Subject to technical changes

In the course of technical progress, KLAUS Multiparking shall be entitled to use newer or different technologies, systems, processes or standards to provide the services than initially offered, provided that this does not disadvantage the customer in any way.

### KLAUS Multiparking GmbH

Hermann-Krum-Straße 2  
88319 Aitrach / Germany

+49 (0) 7565 508-0

info@multiparking.com  
www.multiparking.com