

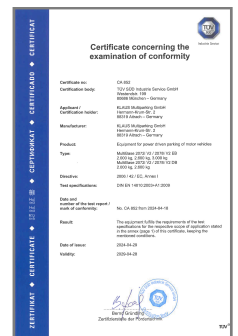

PRODUCT DATA

DIMENSIONS, TECHNICAL INFORMATION AND PERFORMANCE SPECIFICATION

multibase 2072i



Contents

Explanation of symbols.....	2	Entrance inclination.....	8
Parking positions.....	2	Clearances for installations.....	8
Dimensional specifications & tolerances.....	2	Electrical installation.....	9
Overview of building design.....	3	CE conformity.....	10
Vehicle data.....	3	Technical information.....	11
Overview of system types & ceiling heights.....	4	Performance specification.....	12
Width dimensions.....	5	Performances provided by customer.....	13
Width dimensions with door.....	5	Right to technical changes reserved.....	13
Width dimensions without door.....	6		
Loading schedule.....	7		

Explanation of symbols



Platforms accessible horizontally.



Maximum load per parking space in lbs.
Upweights above 4,400 lbs possible with surcharge (see "Vehicle data", page 3).



Parking space accessible for the disabled
Parking possible for persons with restricted mobility (see "Parking space accessible for the disabled", page 11)



The quoted systems correspond to DIN EN 14010 and EU Machinery Directive 2006/42/EC.



In addition, this system has undergone a voluntary conformity test by TÜV SÜD.

Parking positions

Lower parking space

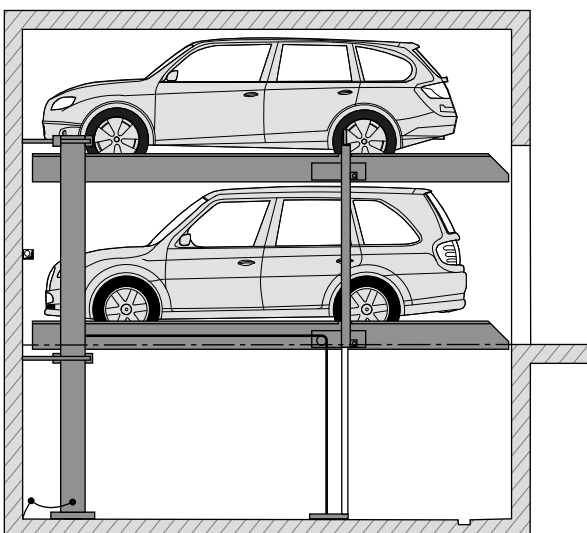

The lower vehicle can enter or exit the parking space.

Upper parking space

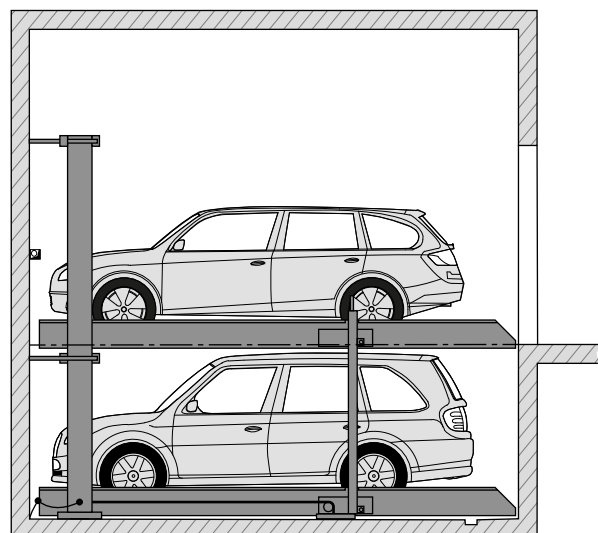

The upper vehicle can enter or exit the parking space.

Dimensional specifications & tolerances



All structural dimensions are minimum finished dimensions.

Tolerance for structural dimensions: +1.2/-0". Dimensions in inches (in).

The tolerances specified in the German Construction Contract Procedures (VOB), Part C (DIN 18330 and 18331) as well as DIN 18202 must also be taken into account in order to adhere to the minimum finish dimensions.

Overview of building design

Building design without door

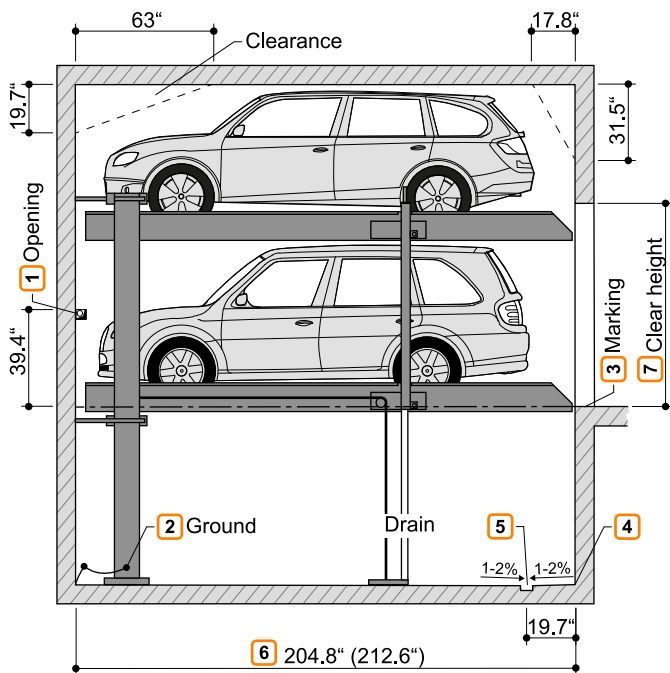

Building design with door

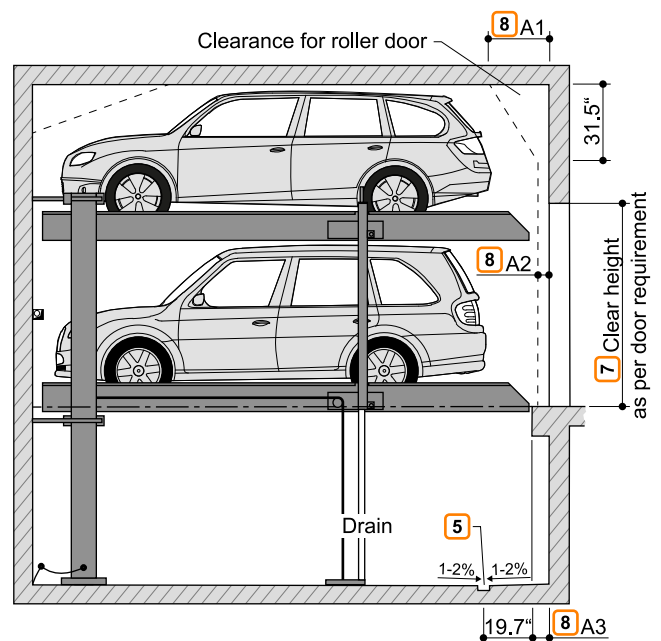

- 1 For dividing walls: Wall opening 4" x 4".
- 2 Equipotential bonding from the foundation ground connection to the system (provided by customer).
- 3 As per DIN EN 14010, the customer must apply a 4" wide gold and black marking as per DIN ISO 3864 at the edge of the pit in the entry area to mark the danger area. (see "Loading schedule", page 7).
- 4 Grooves/concrete haunches are not possible at the transition from the pit floor and the walls. If grooves/concrete haunches are required, then the system must be narrower or the pits wider.

- 5 Slope with water collection channel (see "Drainage", page 13).
- 6
 - 204.7" for vehicles up to 196.9" in length
 - 212.6" for vehicles up to 204.8" in length
 Shorter designs possible upon request. Observe local regulations for parking space length!
 So that you can conveniently use your parking space and due to the ever increasing length of vehicles, we recommend a pit length of 212.6".
- 7 Clear height as per local regulations. At least largest possible vehicle height + 4".
- 8 The customer must coordinate dimension A1, A2 and A3 with the door manufacturer.

Vehicle data

Design

SP (single platform) = 2 vehicles
 DP (double platform) = 4 vehicles

Parking options

Production vehicles:
 Sedan, station wagon, SUV, and van as per clearance gauge and maximum parking space load.

	SP			DP	
Weight	4400 lbs	5720 lbs	6600 lbs	4400 lbs	5720 lbs
Wheel load	1100 lbs	1430 lbs	1650 lbs	1100 lbs	1430 lbs

- 1 Vehicle height (see "Overview of system types & ceiling heights", page 4)
- 2 Vehicle length (see "Overview of building design", page 3)

Clearance gauge

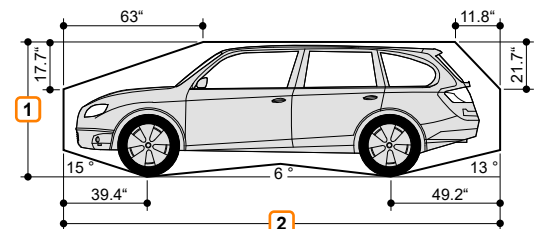

Vehicle width of 74.9" with a platform width of 90.6".
 Wider platforms allow correspondingly wider vehicles to be parked.

Overview of system types & ceiling heights

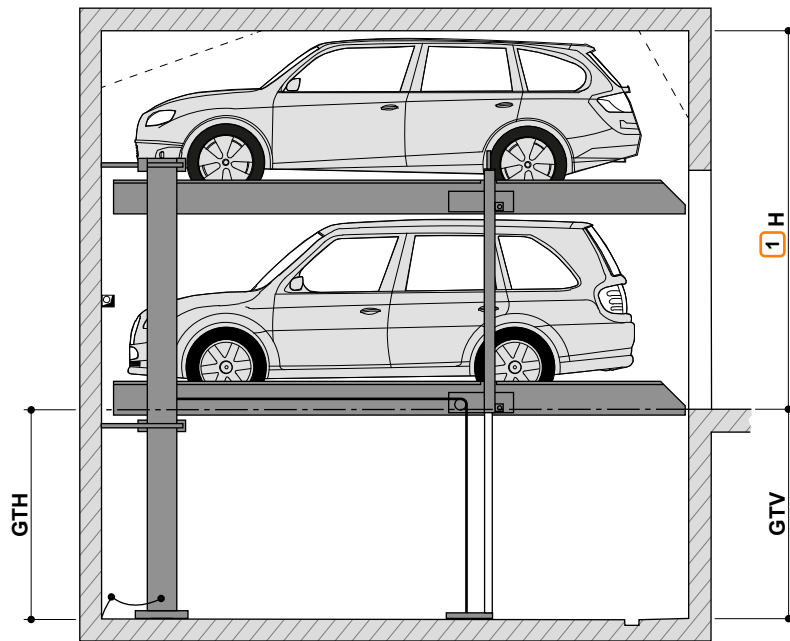

H: Building height:
GTV: pit depth, front
GTH: pit depth, rear

1 A higher ceiling height allows correspondingly taller vehicles to be parked.

Type	GTH	GTV	Lower vehicle height	Upper vehicle height														H - building height [inch (in)]
				59.1"	61.1"	63.0"	65.0"	67.0"	68.9"	70.9"	72.9"	74.9"	76.8"	78.8"	80.8"	82.7"	84.7"	
2072i-165	65.0"	67.0"	59.0"	126.0	128.0	130.0	131.9	133.9	135.9	137.8	139.8	141.8	143.8	145.7	147.7	149.7	151.6	151.6
2072i-170	67.0"	68.9"	61.0"	128.0	130.0	131.9	133.9	135.9	137.8	139.8	141.8	143.8	145.7	147.7	149.7	151.6	153.6	153.6
2072i-175	68.9"	70.9"	63.0"	130.0	131.9	133.9	135.9	137.8	139.8	141.8	143.8	145.7	147.7	149.7	151.6	153.6	155.6	155.6
2072i-180	70.9"	72.9"	65.0"	131.9	133.9	135.9	137.8	139.8	141.8	143.8	145.7	147.7	149.7	151.6	153.6	155.6	157.5	157.5
2072i-185	72.9"	74.9"	67.0"	133.9	135.9	137.8	139.8	141.8	143.8	145.7	147.7	149.7	151.6	153.6	155.6	157.5	159.5	159.5
2072i-190	74.9"	76.8"	68.9"	135.9	137.8	139.8	141.8	143.8	145.7	147.7	149.7	151.6	153.6	155.6	157.5	159.5	161.5	161.5
2072i-195	76.8"	78.8"	70.9"	137.8	139.8	141.8	143.8	145.7	147.7	149.7	151.6	153.6	155.6	157.5	159.5	161.5	163.4	163.4
2072i-205	80.8"	82.7"	74.8"	141.8	143.8	145.7	147.7	149.7	151.6	153.6	155.6	157.5	159.5	161.5	163.4	165.4	167.4	167.4
2072i-215	84.7"	86.7"	78.7"	145.7	147.7	149.7	151.6	153.6	155.6	157.5	159.5	161.5	163.4	165.4	167.4	169.3	171.3	171.3
2072i-220	86.7"	88.6"	80.7"	147.7	149.7	151.6	153.6	155.6	157.5	159.5	161.5	163.4	165.4	167.4	169.3	171.3	173.3	173.3
2072i-230	90.6"	92.6"	84.6"	151.6	153.6	155.6	157.5	159.5	161.5	163.4	165.4	167.4	169.3	171.3	173.3	175.2	177.2	177.2

Configuration example



Example: Lower vehicle height of 63" & upper vehicle height of 74.9".

Type: 2072i - 175

Building height: 145.7"

Type	GTH	GTV	Lower vehicle height	Upper vehicle height														H
				59.1"	61.1"	63.0"	65.0"	67.0"	68.9"	70.9"	72.9"	74.9"	76.8"	78.8"	80.8"	82.7"	84.7"	
2072i-165	65.0"	67.0"	59.1"	126.0	128.0	130.0	131.9	133.9	135.9	137.8	139.8	141.8	143.8	145.7	147.7	149.7	151.6	151.6
2072i-170	67.0"	68.9"	61.1"	128.0	130.0	131.9	133.9	135.9	137.8	139.8	141.8	143.8	145.7	147.7	149.7	151.6	153.6	153.6
2072i-175	68.9"	70.9"	63.0"	130.0	131.9	133.9	135.9	137.8	139.8	141.8	143.8	145.7	147.7	149.7	151.6	153.6	155.6	155.6
2072i-180	70.9"	72.9"	65.0"	131.9	133.9	135.9	137.8	139.8	141.8	143.8	145.7	147.7	149.7	151.6	153.6	155.6	157.5	157.5

Width dimensions



We recommend a platform width of at least 98.5" and driving lane widths of 256" to ensure convenient vehicle access to the multiparking system and easy entry into and exit from the vehicle.

Narrower platforms can make parking more difficult, depending on the following criteria.

- Driving lane width
- Entry conditions
- Vehicle dimensions

- 1 Observe the minimum driving lane width specified by local regulations!

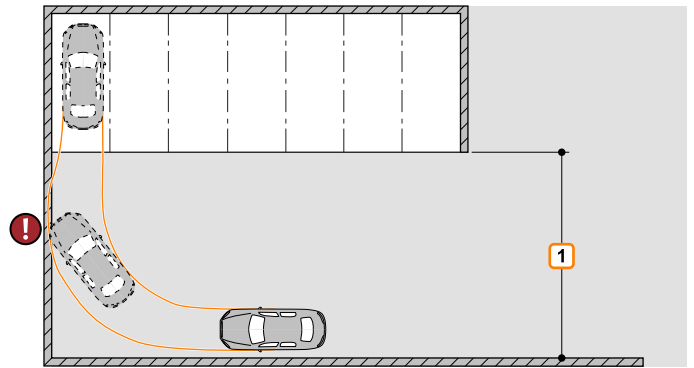

Width dimensions with door

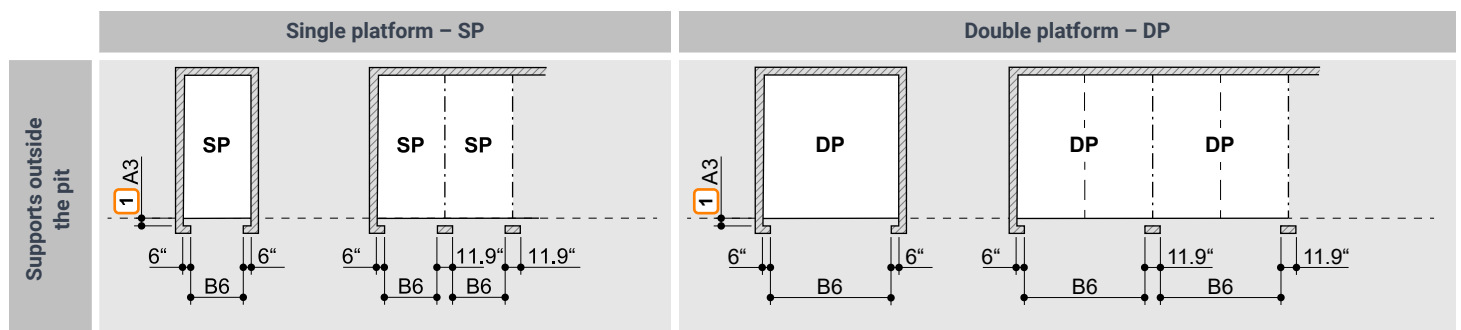

	Clear platform width	Passage width B6
SP	90.6"	90.6"
	94.5"	94.5"
	98.5"	98.5"
	102.4"	102.4"
	108.3"	108.3"
	137.8" 2	137.8"

	Clear platform width	Passage width B6
DP	181.2"	181.2"
	185.1"	181.1"
	189.0"	189.0"
	193.0"	193.0"
	196.9"	196.9"
	200.8"	200.8"
	204.8"	204.8"
	208.7"	208.7"
	212.6"	212.6"

- 1 Door offset (customer must coordinate dimension A3 with the door manufacturer). Lateral closing doors require coordination between the door manufacturer and KLAUS Multiparking.

- 2 Designed as parking space accessible for the disabled

Width dimensions without door

	Single platform – SP	Double platform – DP	Combination as example			
Dividing walls						
Supports in the pit						
Supports outside the pit						
	Clear platform width	Dividing walls B1	Support in the pit B2 B3		Support outside the pit B4 B5	
SP	90.6"	102.4"	100.4"	96.5"	98.5"	94.5"
	94.5"	106.3"	104.4"	100.4"	102.4"	98.5"
	98.5"	110.3"	108.3"	104.4"	106.3"	102.4"
	102.4"	114.2"	112.3"	108.3"	110.3"	106.3"
	106.3"	118.2"	116.2"	112.3"	114.2"	110.3"
	137.8" ¹	149.7"	147.7"	143.8"	145.7"	141.8"
DP	181.2"	193.0"	191.0"	187.5"	189.0"	185.1"
	185.1"	196.9"	194.9"	191.0"	193.0"	189.0"
	189.0"	200.8"	198.9"	194.9"	196.9"	193.0"
	193.0"	204.8"	202.8"	198.9"	200.8"	196.9"
	196.9"	208.7"	206.7"	202.8"	204.8"	200.8"
	200.8"	212.6"	210.7"	206.7"	208.7"	204.8"
	204.8"	216.6"	214.6"	210.7"	212.6"	208.7"
	208.7"	220.5"	218.6"	214.6"	216.6"	212.6"
212.6"	224.5"	222.5"	218.6"	220.5"	216.6"	
Combination	90.6" + 181.2"	295.3"	293.4"	289.4"	291.4"	287.5"
	94.5" + 185.1"	303.2"	301.2"	297.3"	299.3"	295.3"
	98.5" + 189.0"	311.1"	309.1"	305.2"	307.1"	303.2"
	98.5" + 196.9"	318.9"	317.0"	313.0"	315.0"	311.1"
	106.3" + 196.9"	326.8"	324.9"	320.9"	322.9"	318.9"
	106.3" + 200.8"	330.8"	328.8"	324.9"	326.8"	322.9"
	106.3" + 204.8"	334.7"	332.7"	328.8"	330.8"	326.8"
	106.3" + 208.7"	338.6"	336.7"	332.7"	334.7"	330.8"
	106.3" + 212.6"	342.6"	340.6"	336.7"	338.6"	334.7"

¹ Designed as parking space accessible for the disabled

Loading schedule



The systems are doweled to the floor. The depth of the boreholes in the floor plate is approximately 6", and approximately 4.8" in the walls.

Floor plates and walls below the level of the entrance must be made of concrete (concrete quality at least C20/25)!

The dimensions for the bearing points have been rounded. If you need to know the exact position, please contact KLAUS Multiparking.

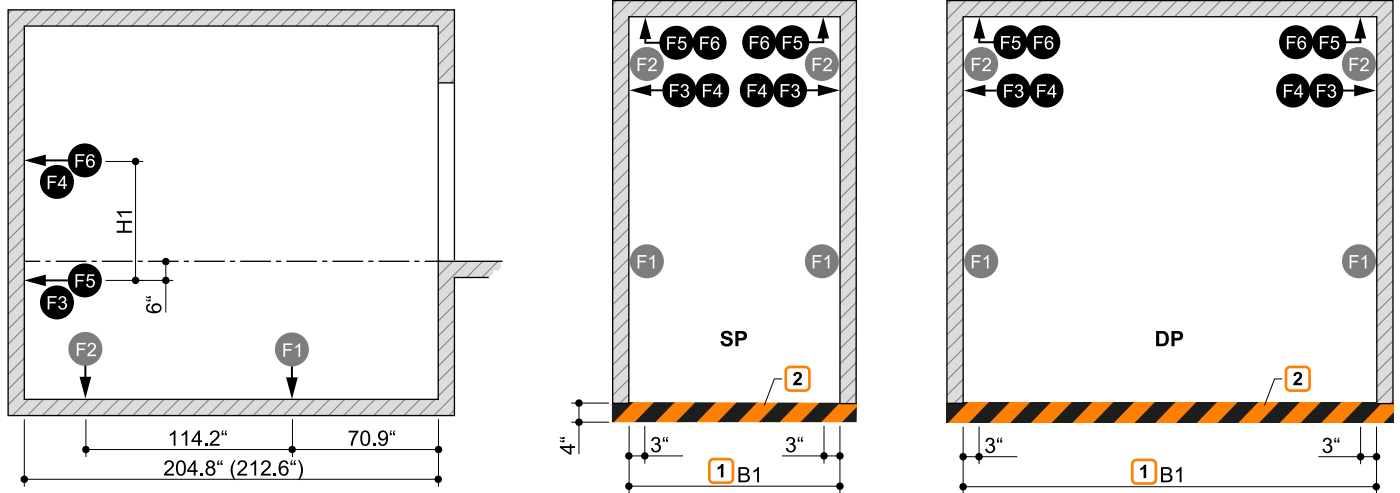

1 Width dimension B1 (see "Width dimensions without door", page 6)

2 Marking in accordance with DIN ISO 3864 (illustration colour not consistent with DIN ISO 3864)

Parking space load	F1	F2	F3	F4	F5	F6	Type	H1
SP	4,400 lbs	+6,295 lbf	+2,698 lbf	±225 lbf	±180 lbf	±248 lbf	2072i-165	82.7"
		-383 lbf					2072i-170	84.7"
	5,720 lbs	+8,094 lbf	+3,373 lbf	±293 lbf	±225 lbf	±315 lbf	2072i-175	86.7"
		-495 lbf					2072i-180	88.6"
6,600 lbs	+9,442 lbf	+3,822 lbf	±338 lbf	±270 lbf	±360 lbf	2072i-185	90.6"	
	-540 lbf					2072i-190	92.6"	
DP	4,400 lbs	+11,466 lbf	+4,497 lbf	±360 lbf	±585 lbf	±450 lbf	2072i-195	94.5"
		-1,507 lbf					2072i-205	98.5"
	5,720 lbs	+15,063 lbf	+5,846 lbf	±473 lbf	±765 lbf	±585 lbf	2072i-215	102.4"
		-1,934 lbf					2072i-220	104.4"
						2072i-230	108.3"	

Entrance inclination



The maximum entry inclinations specified in the sketch must not be exceeded. An incorrect design can make driving into the system considerably more difficult, for which KLAUS Multiparking is not responsible.

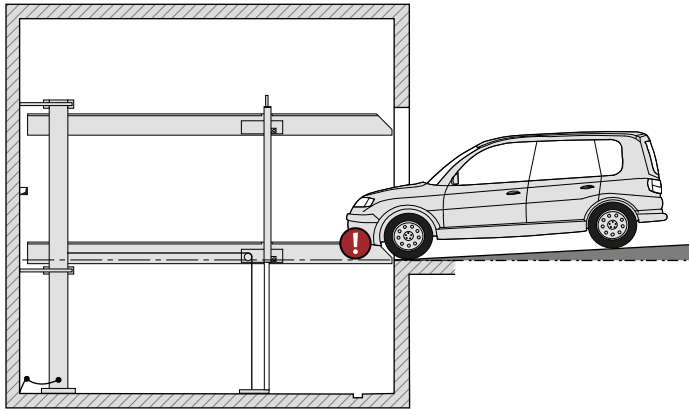

Max. slope: 3%

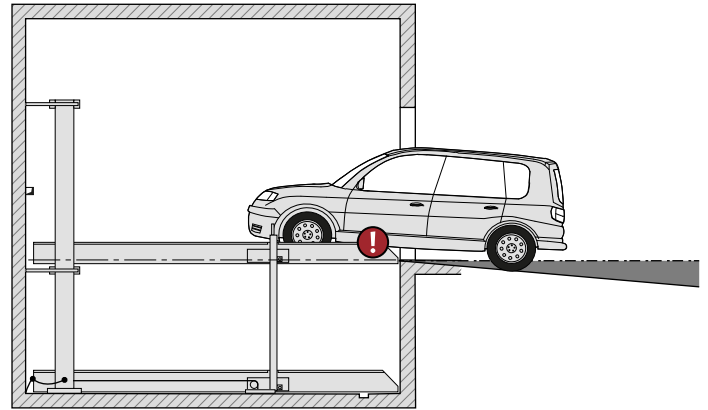

Max. gradient: 10%

Clearances for installations



These clearances apply exclusively to vehicles parked forward with exit on the left. The clearances must be adjusted accordingly for vehicles with exit on the right or if vehicles are backed into the parking space.

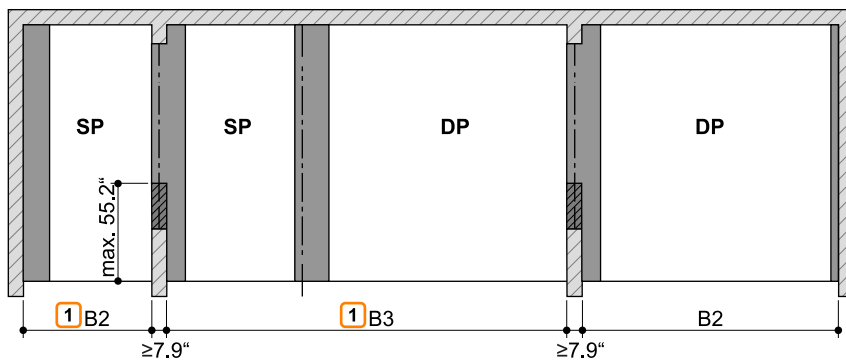
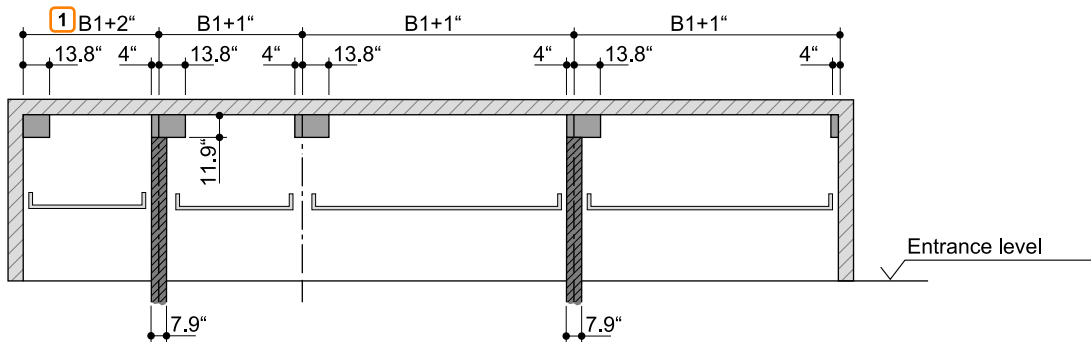

① Dimensions B1, B2 and B3 (see "Width dimensions without door", page 6,)

- Clearance for routing lines lengthways
- Clearance for vertical pipes, ventilation ducts, etc.

Electrical installation

Electrical installation diagram

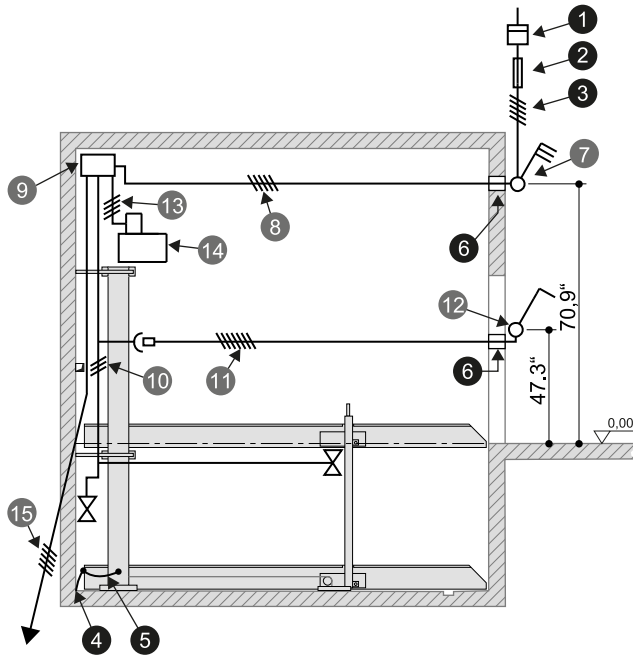

Performances provided by customer for operating elements

Surface-mounted operating element

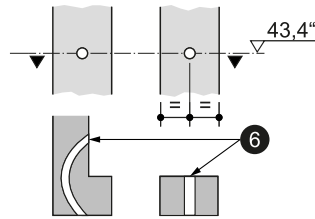

Register of electrical performances (provided by customer)

No.	Quantity	Designation	Position	Frequency
1	1	Power meter	In the supply cable	
2	1	Pre-fuse: 2x fuse 30 A (time-lag) or Circuit breaker 2 x 30 A (tripping characteristic J or CC)	In the supply cable	1x per 3.7-kW unit
		3x fuse 30 A (time-lag) or Circuit breaker 3 x 30 A (tripping characteristic J or CC)	In the supply cable	1x per 4.0-kW unit
3	1	Supply cable 3 x AWG 10 (2 PH+N+PE) with labeled conductors and protective ground	to master switch	1x per 3.7-kW unit
		Supply cable 4 x AWG 10 (3 PH+N+PE) with labeled conductors and protective ground	to master switch	1x per 4.0-kW unit
4	every 393.8"	Foundation ground connection	Corner of pit floor	
5	1	Equipotential bonding as per NEC or CSA from the foundation ground connection to the system		1x per system
6	2	Empty conduit EN 25 (M25)		

Register of electrical performances – in conformity with UL/CSA (scope of supply of KLAUS Multiparking)

No.	Designation
7	Lockable master switch
8	Supply cable 4 x AWG 10 (2 PH+N+PE) with labeled conductors and protective ground for 3.7-kW unit
	Supply cable 4 x AWG 12 (3 PH+N+PE) with labeled conductors and protective ground for 4.0-kW unit
9	Switch cabinet
10	Multiparker cable harness
11	Connection cable (operating element)
12	Operating element
13	Control cable 3 x AWG 10 with labeled conductors and protective ground for 3.7-kW unit
	Control cable 4 x AWG 12 with labeled conductors and protective ground for 4.0-kW unit
14	Hydraulic unit, 3.7 kW, two-phase current, 240 V / 60 Hz
	Hydraulic unit, 4.0 kW, three-phase current, 120/208 V / 60 Hz
15	Connection cable to the next system

CE conformity

The quoted systems correspond to DIN EN 14010 and EU Machinery Directive 2006/42/EC. In addition, this system has undergone a voluntary conformity test by TÜV SÜD.

ZERTIFIKAT ◆ CERTIFICATE ◆ 認証証書 ◆ CERTIFICADO ◆ CERTIFICAT	 Industrie Service
	<h2>Certificate concerning the examination of conformity</h2>
	Certificate no: CA 852
	Certification body: TÜV SÜD Industrie Service GmbH Westendstr. 199 80686 München – Germany
	Applicant / Certification holder: KLAUS Multiparking GmbH Hermann-Krum-Str. 2 88319 Aitrach – Germany
	Manufacturer: KLAUS Multiparking GmbH Hermann-Krum-Str. 2 88319 Aitrach – Germany
	Product: Equipment for power driven parking of motor vehicles
	Type: MultiBase 2072i V2 / 2078i V2 EB 2.000 kg, 2.600 kg, 3.000 kg MultiBase 2072i V2 / 2078i V2 DB 2.000 kg, 2.600 kg
	Directive: 2006 / 42 / EC, Annex I
	Test specifications: DIN EN 14010:2003+A1:2009
Date and number of the test report / mark of conformity: No. CA 852 from 2024-04-18	
Result: The equipment fulfills the requirements of the test specifications for the respective scope of application stated in the annex (page 1) of this certificate, keeping the mentioned conditions.	
Date of issue: 2024-04-29	
Validity: 2029-04-28	
 Bernd Gründling Zertifizierstelle der Pördertechnik	
	
TÜV®	

Technical information

Area of use

In general, the system is best suited for a fixed group of users. Structural adjustments to the multiparking system are required to accommodate a changing group of users (only in the upper parking spaces), e.g., short-term parkers in office buildings or hotels. If needed, please contact us.

Parking space accessible for the disabled

Designed as parking space accessible for the disabled as per Recommendation DIN 18040 (Construction of Accessible Buildings – Design Principles) with the following specifications:

- Platform width of 137.8"
- Platform accessible horizontally (1° gradient)
- AluLongLife platform profiles
- Operating element with key blocking

Note: AluLongLife on the top platform facilitates access on foot or by wheelchair. The key blocking feature of the operating element ensures that the key can only be removed when the system is lowered. This ensures that the upper parking space is available for access at all times.

Units

Low-noise power units mounted to rubber-bonded-to metal mountings are installed. Nevertheless, we recommend separating the garage body from the residential building.

Environmental conditions

Environmental conditions for the area of multiparking systems. Temperature range -4 to +104° F. Relative humidity 50% and a maximum outside temperature of +104° F. If raising and lowering times are specified, they refer to an ambient temperature of +50° F and a system arranged directly next to the hydraulic unit. These times increase at lower temperatures or with longer hydraulic lines.

Seismic considerations

Local seismic conditions might require special precautionary measures such as struts. Please contact KLAUS Multiparking for seismic reports and advice.

Building permit documents

Multiparking systems are usually subject to approval. Please observe local regulations and ordinances in this regard.

Care

To prevent corrosion damage, please observe our separate cleaning and care instructions, and make sure that your garage is well ventilated.

Corrosion protection

As per "Corrosion Protection" supplement.

Railing

If the permissible fall opening is exceeded, railings are attached to the systems. If traffic routes are located immediately next to or behind the systems, then the customer must provide barriers as per DIN EN ISO 13857. This applies during the construction phase as well.

Noise protection

Normal noise protection:

As per DIN 4109-1 "Sound Insulation in Buildings – Part 1: Minimum Requirements," section 9:

The maximum sound pressure level in living and sleeping spaces is 30 dB (A).

User noises are not subject to the requirements.

The following actions are required to comply with this value:

- Noise protection package as per quotation/order (KLAUS Multiparking)
- Sound reduction index of the structure at least $R'w = 57$ dB (customer-provided performance)

Increased noise protection (separate agreement):

As per DIN 4109-5 "Sound Insulation in Buildings – Part 5: Increased Requirements," section 8:

Maximum sound pressure level in living and sleeping spaces 25 dB (A).

User noises are not subject to the requirements.

The following actions are required to comply with this value:

- Noise protection package as per quotation/order (KLAUS Multiparking)
- Sound reduction index of the structure at least $R'w = 62$ dB (customer-provided performance)

Note:

User noises are noises that can be influenced individually by the user of our multiparking systems. This includes, e.g., driving onto the platform, slamming vehicle doors, engine noises and breaking noises.

Performance specification

Description

Multiparking system for independent parking of 2 vehicles (single platform – SP), 2 x 2 vehicles (double platform – DP) on top of each other.

Dimensions as per the underlying pit, width and height dimensions.

The parking spaces are accessed horizontally and have a slope of $\pm 1^\circ$ to ensure proper drainage of the platforms.

The special arrangement of the lifting and bearing structure allows doors to be opened without restrictions.

A vehicle positioning aid is mounted on one side of each parking space (must be adjusted as per operating instructions).

Operation using one operating element with automatic return via common key.

The operating element is usually attached in front of the support or outside on the door jamb.

Brief instruction at each operating point.

In the case of a building design with a door, special dimensions must be observed.

Multiparking system consisting of:

- 2 columns (anchored to the floor)
- 2 sliding pieces (with slideways fastened to the columns)
- 2 platforms
- 1 electrohydraulic synchronization system (to ensure that the hydraulic cylinders run synchronously during raising and lowering)
- 2 hydraulic cylinders
- 2 rigid supports (connection of the platforms)
- 2 chains and chain deflection pulleys
- Dowels, bolts, fasteners, pins, etc.
- The platforms are end-to-end accessible for parking!

Platforms consisting of:

- Platform profiles
- Adjustable positioning aid
- Chamfered access plates
- Side beams
- Center beam (DP only)
- Crossbeams (long and short crossbeams for DP)
- Railings (on the top and bottom platform, if needed)
- Bolts, nuts, washers, spacer tubes, etc.

Hydraulic system consisting of:

- Hydraulic cylinders
- Solenoid valves
- Hydraulic lines
- Threaded connections
- High-pressure hoses
- Fasteners

Electrical system consisting of:

- Operating element (emergency-stop, lock, 1 common key per parking space)
- Control unit with wiring harness and sensors

Hydraulic unit consisting of:

- Hydraulic unit (low-noise, mounted on a console with rubber-bonded-to-metal mountings)
- Hydraulic oil tank
- Oil fill
- Internal gear pump
- Pump carrier
- Coupling
- Three-phase motor
- Contactor, motor protection switch and control fuse
- Test pressure gage
- Pressure relief valve
- Hydraulic hoses (damping of noise transmission to the hydraulic pipes)

Performances provided by customer

Barriers

Any barriers required to secure the parking system pit due to traffic routes located immediately in front of, next to or behind the systems as per DIN EN ISO 13857. This applies during the construction phase as well. Any railings needed on the systems are included as standard.

Parking space numbering

Any parking space numbering required.

Technical building systems

Any required lighting, ventilation, fire extinguishing systems and fire alarm systems, as well as clarification and fulfillment of the associated legal requirements.

Lighting

The customer must observe local regulations regarding the lighting of parking spaces and roadways. As per DIN EN 12464-1 "Light and Lighting – Lighting of Work Places – Part 1: Indoor Work Places" an illuminance of at least 200 lx is recommended for parking spaces and the operating area of the system.

Drainage

Functional drainage of the pit provided by, e.g., a water collection channel in the front area connected to the sewer system or a sump. A lateral slope is possible within the channel but not in the rest of the pit area (a lengthways slope is provided by the structural dimension). As an environmental protection measure, we recommend that the pit floor be painted. Oil or gasoline separators must be appropriately taken into account as per local regulations when the drain is attached to the sewer system.

Strip foundations

If strip foundations are used for structural reasons, the customer must construct a walkable platform at the height of the upper edge of the strip foundations so that the assembly work can be performed.

Warning markings

As per DIN EN 14010, the customer must apply a 4" wide gold and black marking as per DIN ISO 3864 at the edge of the pit in the entry area to mark the danger area.

Wall openings

Any required wall openings as per sectional drawings (see "Overview of building design", page 3).

Supply cable to the master switch – foundation ground

The customer must provide the supply cable to the master switch during assembly. Our fitter can check functionality on site together with the electronics technician. If this is not possible during assembly due to reasons for which the customer is responsible, then the customer must contract an electronics technician.

The customer must ground the steel structure using the foundation ground connection (max. ground distance 393.8") and equipotential bonding as per DIN EN 60204.

Operating element

Empty conduits and cutouts for the operating elements (see "Electrical installation", page 9). Consultation with KLAUS Multiparking is required for folding doors.

Right to technical changes reserved.

In carrying out its performances in the course of technical progress, KLAUS Multiparking is free to use new or different technologies, systems, processes or standards than those initially quoted, provided this does not result in any disadvantages for the customer.

KLAUS Multiparking GmbH

Hermann-Krum-Straße 2
88319 Aitrach / Germany

+49 (0) 7565 508-0

info@multiparking.com
www.multiparking.com

KLAUS Multiparking America Inc.

350 Fifth Avenue, #5220
New York, 10118

+1 848 900 1074

america@multiparking.com
www.multiparkingusa.com

