

# Product Data

Dimensions, Technical Information and Performance Specification



## multibase U10 EB



## Contents

|   |   |  |    |
|---|---|--|----|
| Explanation of symbols.....                       | 2 | Loading schedule.....                    | 9  |
| Parking positions.....                            | 2 | Entrance inclination.....                | 9  |
| Dimensional specifications & tolerances.....      | 3 | Electrical installation.....             | 10 |
| Overview of building design.....                  | 3 | CE conformity.....                       | 11 |
| Vehicle data.....                                 | 4 | Technical information.....               | 12 |
| Overview of system types & ceiling heights.....   | 4 | Condensation water.....                  | 12 |
| Width dimensions.....                             | 5 | Performance specification.....           | 13 |
| Detail of building configuration - pit floor..... | 7 | Performances provided by customer.....   | 13 |
| Detail of building configuration - pit edge.....  | 7 | Right to technical changes reserved..... | 14 |
| Detail of building design – trough seal.....      | 8 |  |    |

## Explanation of symbols



Platforms accessible horizontally.



Maximum load per parking space in lbs.  
Upweights above 4,400 lbs possible with surcharge (see "Vehicle data", page 4).



Outdoor setup.



The quoted systems correspond to DIN EN 14010 and EU Machinery Directive 2006/42/EC.



In addition, this system has undergone a voluntary conformity test by TÜV SÜD.

## Parking positions

### Lower parking space

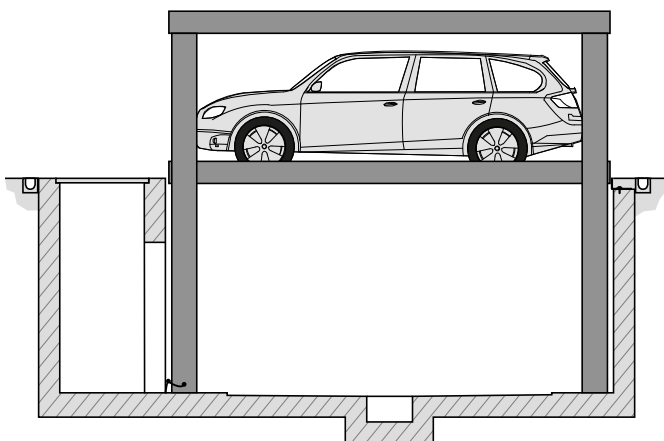

The lower vehicle can enter or exit the parking space.

### Upper parking space

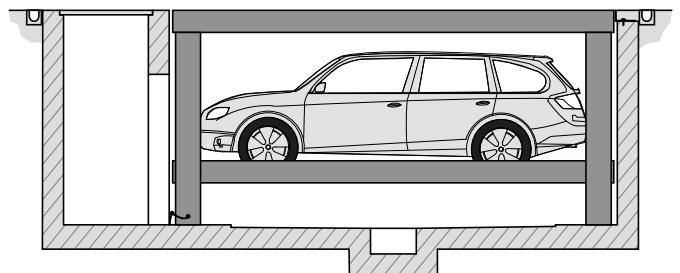

The upper parking space may be used under specific conditions.

## Dimensional specifications & tolerances



All structural dimensions are minimum finished dimensions.

Tolerance for structural dimensions: +1,2/-0". Dimensions in inches (in).

The tolerances specified in the German Construction Contract Procedures (VOB), Part C (DIN 18330 and 18331) as well as DIN 18202 must also be taken into account in order to adhere to the minimum finish dimensions.

## Overview of building design

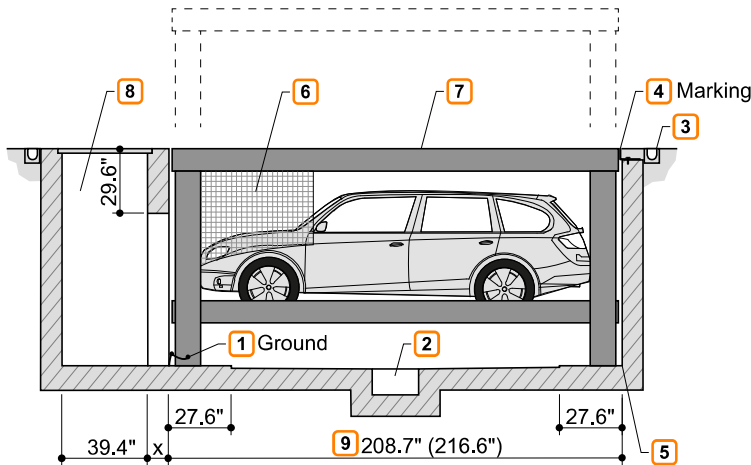

- 1 Equipotential bonding from the foundation ground connection to the system (provided by customer).
- 2 Slope with water collection channel (see "Detail of building configuration - pit floor", page 7, see "Drainage", page 13).
- 3 Pit edge (see "Detail of building configuration - pit edge", page 7).
- 4 As per DIN EN 14010, the customer must apply a 4" wide gold and black marking as per DIN ISO 3864 at the edge of the pit in the entry area to mark the danger area. (see "Loading schedule", page 9).
- 5 Grooves/concrete haunches are not possible at the transition from the pit floor and the walls. If grooves/concrete haunches are required, then the system must be narrower or the pits wider.
- 6 Protective grilles are installed in the side and rear area. This requirement can be waived under certain structural conditions. Consultation with KLAUS Multiparking is required.
- 7 The top platform is a frame structure. The customer can install floor coverings (e.g., soil/grass, sand bed/grass pavers, sand bed/marble, etc.) Maximum weight of the covering provided by the customer: 0.35 lbs/in<sup>2</sup>.  
Trough seal (see "Detail of building design – trough seal", page 8).  
The top platform is level with the ground and can be accessed in the lowered state (max. vehicle weight: ; max. wheel load: 1,430 lbs). The top platform can be used as a parking space under certain conditions.
- 8 A separate on-site maintenance shaft is required (with shaft cover, shaft ladder and passage to pit). The customer must secure the access to the maintenance shaft – consultation with KLAUS Multiparking required. The maintenance shaft also accommodates the hydraulic unit.
- 9
  - 208.7" for vehicles up to 196.9" in length
  - 216.6" for vehicles up to 204.8" in length
 Observe local regulations for parking space length!  
So that you can conveniently use your parking space and due to the ever increasing length of vehicles, we recommend a pit length of 216.6".



After operation, the system must be moved into the lowermost limit position (key blocking).

## Vehicle data

### Design

SP (single platform) = 1 vehicle + 1 vehicle on the upper platform  
(see "Overview of building design", page 3)

### Parking options

Production vehicles:  
Sedan, station wagon, SUV, and van as per clearance gauge and maximum parking space load.

For countries in which snow loads do *not* have to be taken into account:

|            | SP - upper<br>Parking space | SP - lower<br>Parking space |           |
|------------|-----------------------------|-----------------------------|-----------|
| Weight     | 5,720 lbs                   | 4,400 lbs                   | 5,720 lbs |
| Wheel load | 1,430 lbs                   | 1,100 lbs                   | 1,430 lbs |

Vehicle data For countries in which snow loads have to be taken into account, the parking option in the upper parking space is reduced as per the following table:

|            | SP - upper<br>Parking space |
|------------|-----------------------------|
| Weight     | 4,400 lbs                   |
| Wheel load | 1,100 lbs                   |

- 1 Vehicle height (see "Overview of system types & ceiling heights", page 4)
- 2 Vehicle length (see "Overview of building design", page 3)



The snow loads apply to a snow height of 7.9". In the case of greater snow heights, the snow load must be cleared accordingly.

### Clearance gauge

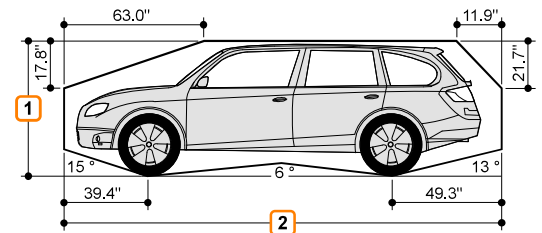

Vehicle width of 74.9" with a platform width of 90.6".  
Wider platforms allow correspondingly wider vehicles to be parked.

## Overview of system types & ceiling heights



If structural circumstances do not limit the height, the vehicle height on the upper parking spaces is not restricted.

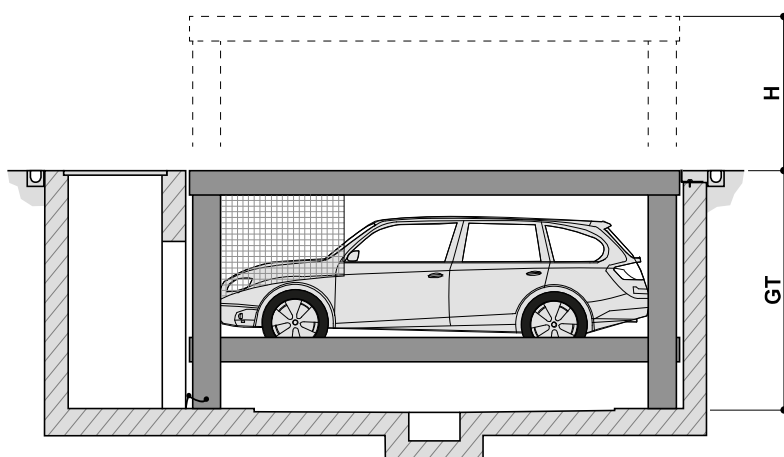

| Type       | GT     | H     | Vehicle height lower |
|------------|--------|-------|----------------------|
| U10 EB-250 | 98.5"  | 82.7" | 65.0"                |
| U10 EB-285 | 112.3" | 96.5" | 78.8"                |

H: Height extended  
GT: Pit depth

## Width dimensions



We recommend a platform width of at least 98.5" and driving lane widths of 256" to ensure convenient vehicle access to the multiparking system and easy entry into and exit from the vehicle.

Narrower platforms can make parking more difficult, depending on the following criteria.

- Driving lane width
- Entry conditions
- Vehicle dimensions

- 1 Observe the minimum driving lane width specified by local regulations!

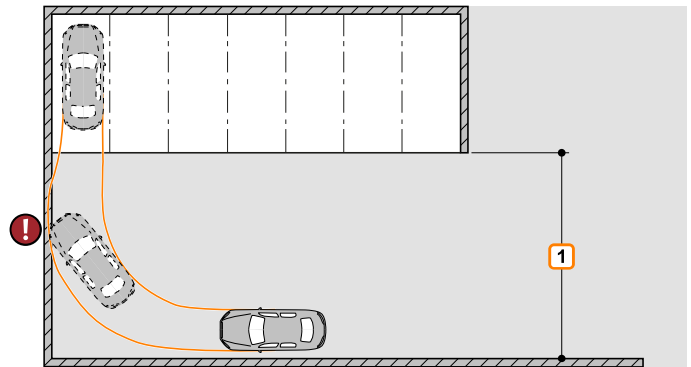

All side walls must be at a right angle. Deviation max. 0.4"!

Attention: If the sides or rear are freely accessible, safeguards are required (barriers, protective grilles, marking, etc.). Measures will be determined on a project-by-project basis.

|                      | Plan view<br>Closed pit                        |  | Pit dimensions                    |            |
|----------------------|--|--|-----------------------------------|------------|
|                      |  |  | Plan view                         | Front view |
| Single platform – SP |  |  |                                   |            |
|                      | <b>Clear platform width<br/>Parking levels</b> | <b>platform width<br/>Upper platform</b> | <b>Single platform – SP<br/>B</b> |            |
| SP                   | 90.6"  | 106.3"                                   | 108.3"                            |            |
|                      | 94.5"  | 110.3"                                   | 112.3"                            |            |
|                      | 94.5"  | 114.2"                                   | 116.2"                            |            |
|                      | 102.4"   | 118.2"                                   | 120.1"                            |            |
|                      | 106.3"   | 122.1"                                   | 124.1"                            |            |

1 The shaft cover must be secured (provided by customer).

2 For dividing walls: Wall opening 6" x 6".

|   | Single platform – SP                   |                                  | Pit dimensions                                    |   |
|---|--|----------------------------------|---|---|
|   |  |                                  | Plan view   | Front view                                |
| 2x single platform - SP<br>without dividing walls |  |                                  |   |   |
|   |  |                                  |   |   |
| Series system<br>with dividing walls              |  |                                  |   |   |
|   |  |                                  |   |   |
|   | Clear platform width<br>Parking levels | platform width<br>Upper platform | 2x single platform<br>without dividing walls<br>C | Series system<br>with dividing walls<br>B |
| SP  | 90.6"                                  | 106.3"                           | 215.6"  | 108.3"                                    |
|   | 94.5"                                  | 110.3"                           | 223.5"  | 112.3"                                    |
|   | 98.5"                                  | 114.2"                           | 231.3"  | 116.2"                                    |
|   | 102.4"                                 | 118.2"                           | 239.2"  | 120.1"                                    |
|   | 106.3"                                 | 122.1"                           | 247.1"  | 124.1"                                    |

- 1 The shaft cover must be secured (provided by customer).
- 2 For dividing walls: Wall opening 6" x 6".
- 3 The passage to the adjacent system must have the same height as the passage from the maintenance shaft in the pit.

## Detail of building configuration - pit floor

### Drainage

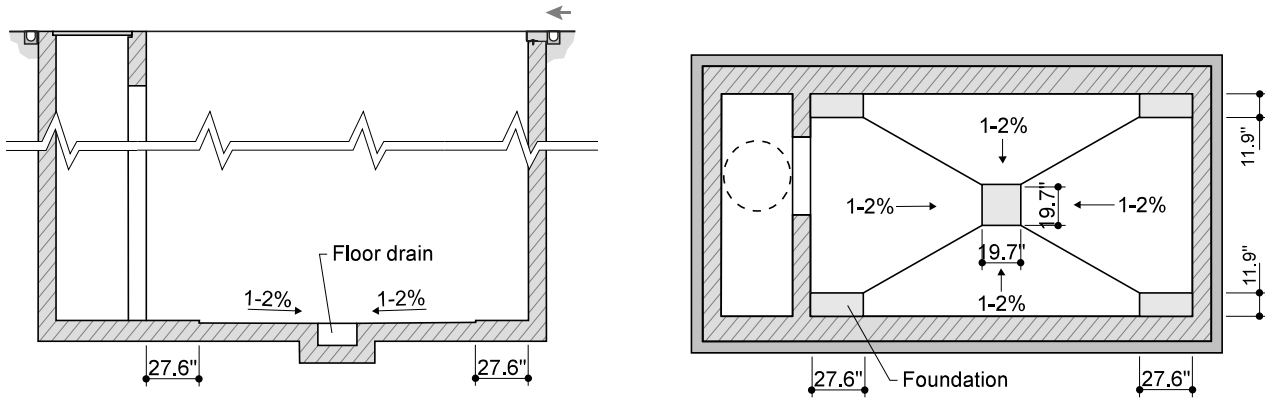

## Detail of building configuration - pit edge



Maximum weight of the covering provided by the customer: 0.35 lbs/in<sup>2</sup>.

### Covering to be provided by the customer - asphalt or concrete

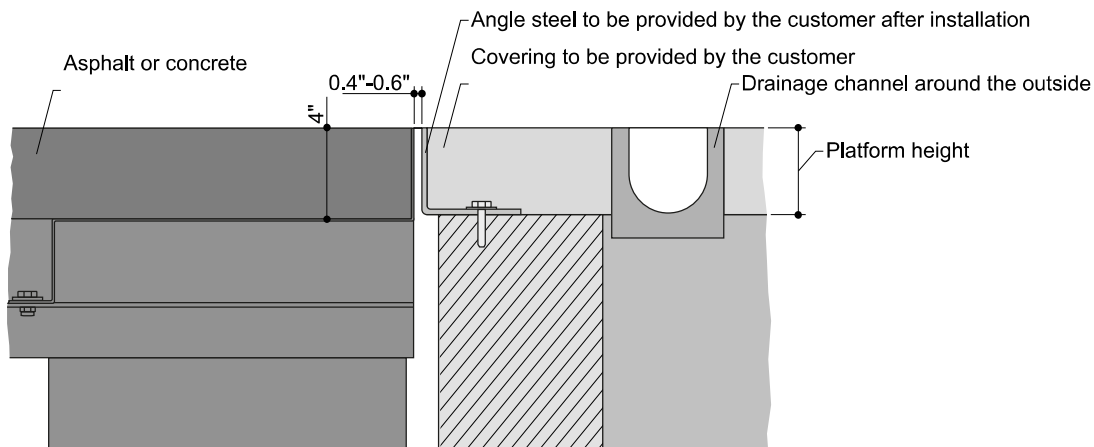

### Covering to be provided by the customer - paving stones

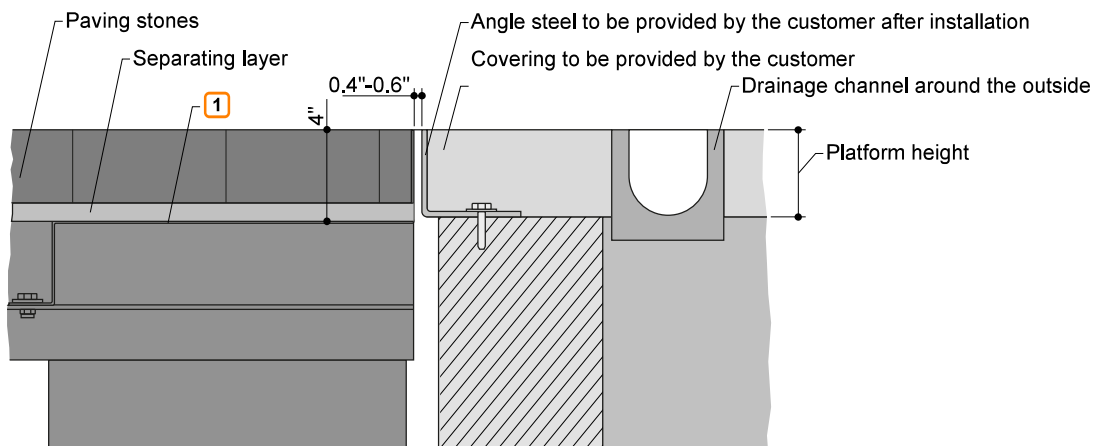

**1** Trough seal (see "Detail of building design – trough seal", page 8)

## Detail of building design – trough seal



The layer structure is only a suggestion. Comparable sealing systems are also possible, but they must be matched to the intended on-site application. Position all components in accordance with the processing instructions of the manufacturer.

### Example structure of trough seal

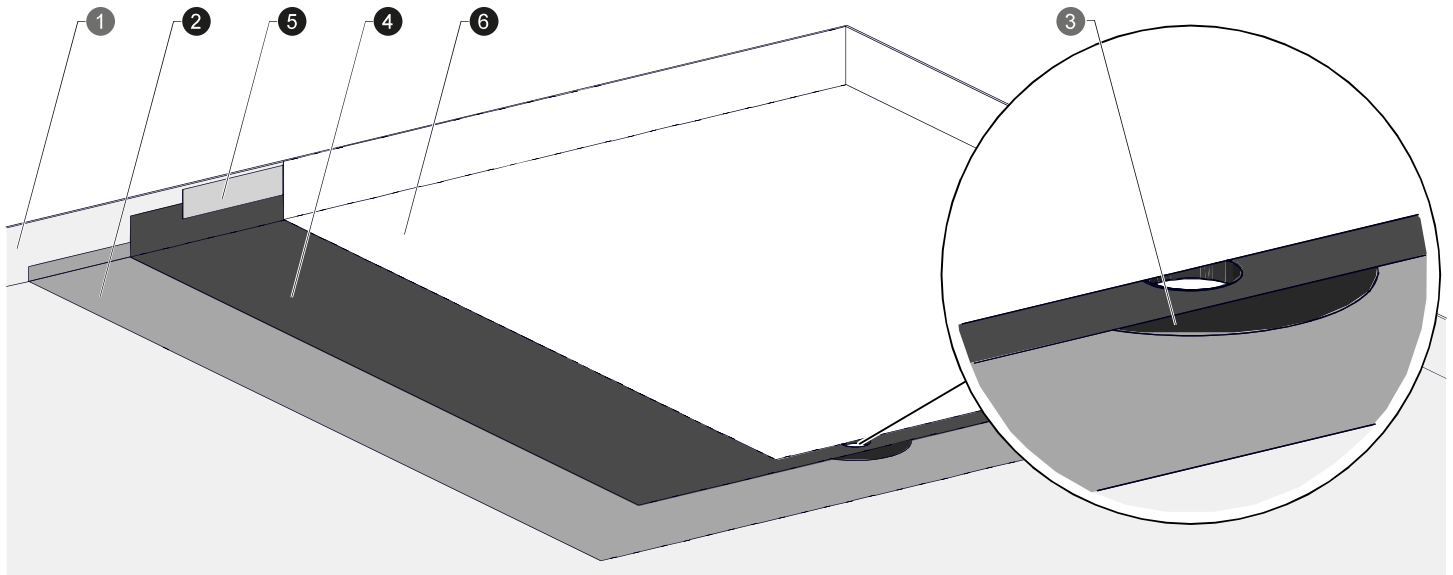

### List of performances for seal

| No. | Layer            | Recommended design  | Scope of supply                  |
|-----|------------------|---|----------------------------------|
| 1   | Trough           | Top platform of the MultiBase U10 /U20 as frame construction.   | KLAUS Multiparking               |
| 2   | Separating layer | Nonwoven pond lining, approximately 9 oz/yd <sup>2</sup> laid over entire area. Cover corner connections and protruding bolts as well, and bond with suitable adhesive. | Performance provided by customer |
| 3   | Drain            | PVC film flange with diameter of 2"; to be bonded to the seal by the customer.  | KLAUS Multiparking               |
| 4   | Seal             | PVC pond film of thickness 20 mil laid over the entire area. Use a suitable adhesive to bond the pond film and film flange over the entire area.                        | Performance provided by customer |
| 5   | Edge fastening   | High-performance adhesive tape of dimension 2" to attach the seal all around.   | Performance provided by customer |
| 5   | Protective layer | Nonwoven pond lining, approximately 15 oz/yd <sup>2</sup> laid over entire area and extending beyond the border of the trough.  | Performance provided by customer |



## Loading schedule



The systems are doweled to the floor. The drill hole depth in the floor plate is approx. 6", in the walls approx. 4.8".  
The floor plate and walls must be of concrete (concrete quality min. C20/25)!  
The dimensions for the bearing points have been rounded. If you need to know the exact position, please contact KLAUS Multiparking.

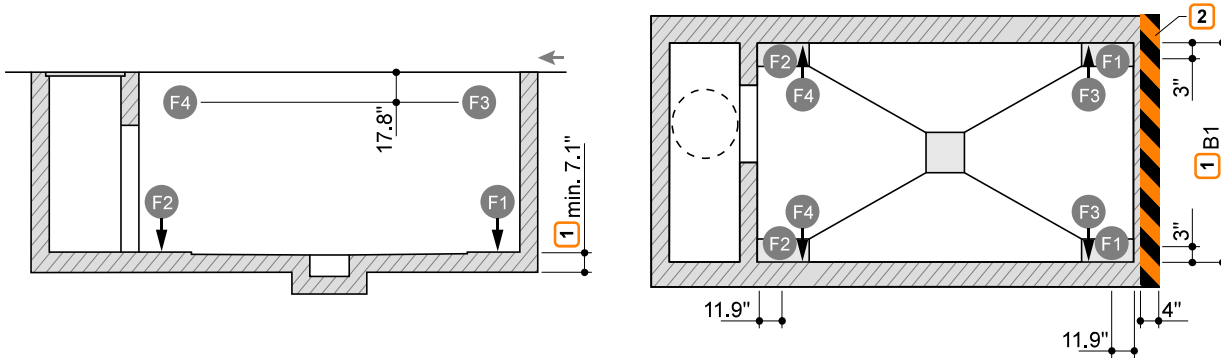

| Parking space load | F1        | F2                       | F3 <sup>4</sup>          | F4 <sup>4</sup> |            |
|--------------------|-----------|--------------------------|--------------------------|-----------------|------------|
| V1 <sup>5</sup>    | 4,400 lbs | + 7419 lbf<br>- 338 lbf  | + 6295 lbf<br>- 900 lbf  | ± 3013 lbf      | ± 2361 lbf |
|                    | 5,720 lbs | + 7869 lbf<br>- 360 lbf  | + 6520 lbf<br>- 990 lbf  | ± 3080 lbf      | ± 2383 lbf |
| V2 <sup>5</sup>    | 4,400 lbs | + 10342 lbf<br>- 473 lbf | + 8768 lbf<br>- 1283 lbf | ± 3485 lbf      | ± 2473 lbf |
|                    | 5,720 lbs | + 10791 lbf<br>- 495 lbf | + 8993 lbf<br>- 1372 lbf | ± 3575 lbf      | ± 2496 lbf |

- <sup>1</sup> Width dimension B (see "Width dimensions", page 5)
- <sup>2</sup> Marking as per DIN ISO 3864 (coloring of the marking corresponds to DIN ISO 3864)
- <sup>3</sup> The bearing capacity of the floor plate must be verified by a structural engineer. In some cases, a thicker floor plate may be required.
- <sup>4</sup> Forces F3 and F4 are reduced by 2,024 lbf for wind-protected installation.
- <sup>5</sup> V1 = top platform with sheet covering | V2 = top platform with stone covering

## Entrance inclination



The maximum entry inclinations specified in the sketch must not be exceeded.  
An incorrect design can make driving into the system considerably more difficult, for which KLAUS Multiparking is not responsible.  
A drainage channel at the entrance is recommended for aboveground garages on a slope.

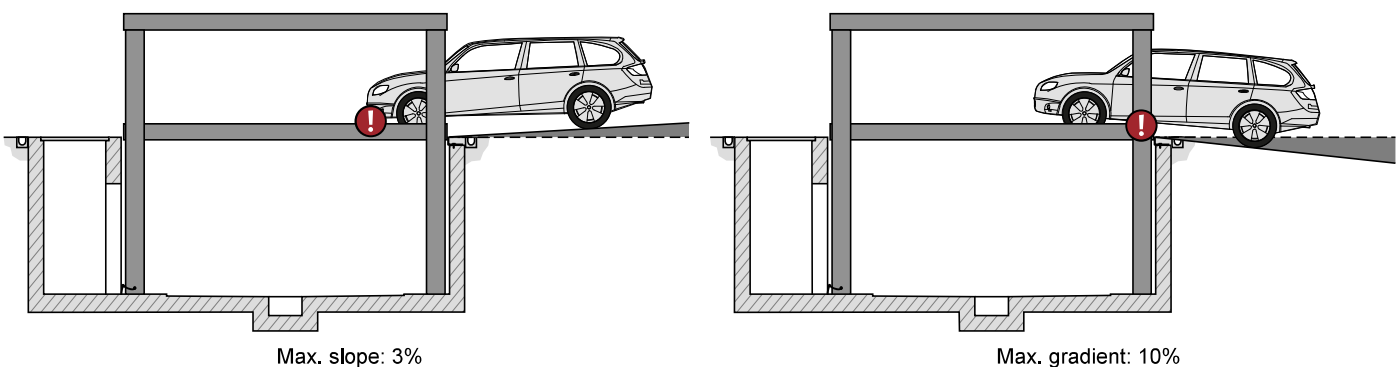

## Electrical installation

### Electrical installation diagram

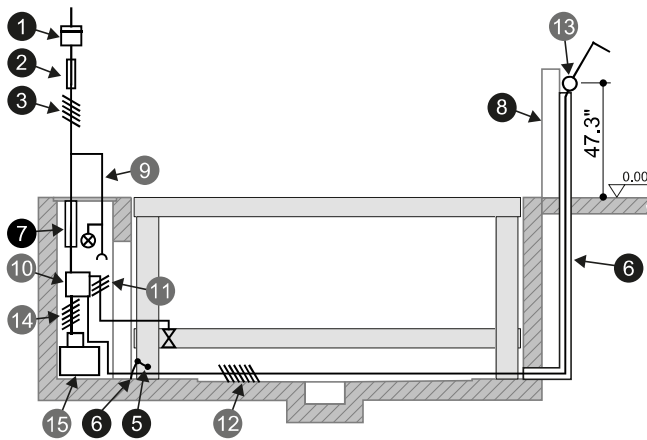

### Performances provided by customer for operating elements

#### Surface-mounted operating element

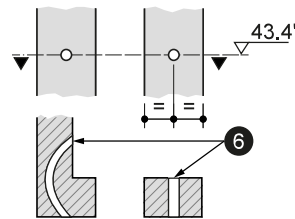

### Register of electrical performances (provided by customer)

| No. | Quantity     | Designation  | Position                             | Frequency          |
|-----|--------------|--|--------------------------------------|--------------------|
| 1   | 1            | Power meter  | In the supply cable                  |                    |
| 2   | 1            | Pre-fuse:<br>2x fuse 32 A (time-lag) or<br>Circuit breaker 2 x 32 (tripping characteristic K or C) | In the supply cable                  | 1x per 3.7-kW unit |
|     | 1            | 3x fuse 25 A (time-lag) or<br>Circuit breaker 3 x 25 A (tripping characteristic K or C)            | In the supply cable                  | 1x per 4.0-kW unit |
| 3   | 1            | Supply cable 4 x AWG 10 (2 PH+N+PE) with labeled conductors and protective ground                  | to master switch                     | 1x per 3.7-kW unit |
|     | 1            | Supply cable 5 x AWG 12 (3 PH+N+PE) with labeled conductors and protective ground                  | to master switch                     | 1x per 4.0-kW unit |
| 4   | Every 393.8" | Foundation ground connection   | Corner of pit floor                  |                    |
| 5   | 1            | Equipotential bonding as per DIN EN 60204 from the foundation ground connection to the system      |                                      | 1x per system      |
| 6   | 1            | Empty conduit EN 25 (M25) with taut wire   | from pit floor to operating element  | 1x per system      |
| 7   | 1            | Empty conduit EN 50 (M50) with taut wire   | Supply cable to unit                 | 1x per unit        |
| 8   | 1            | Operating stands   |                                      | 1x per system      |
| 9   | 1            | separate 120-V supply cable with lighting and socket   | from the supply cable into the shaft | 1x per system      |

### Register of electrical performances – in conformity with UL/CSA (scope of supply of KLAUS Multiparking)

| No. | Designation  |
|-----|--|
| 10  | Switch cabinet with lockable master switch                             |
| 11  | Control cable 3 x AWG 16 with labeled conductors and protective ground |
| 12  | Control cable 7 x AWG 16 with labeled conductors and protective ground |
| 13  | Operating element  |
| 14  | Control cable 4 x AWG 14 with labeled conductors and protective ground |
| 15  | Hydraulic unit, 3.7 kW, two-phase current, 240 V / 60 Hz               |
|     | Hydraulic unit, 4.0 kW, three-phase current, 120/208 V / 60 Hz         |

## CE conformity

The quoted systems correspond to DIN EN 14010 and EU Machinery Directive 2006/42/EC. In addition, this system has undergone a voluntary conformity test by TÜV SÜD.

|  |  |  |
|--|--|--|
| ZERTIFIKAT ◆ CERTIFICATE ◆ 認証証書 ◆ CERTIFICADO ◆ CERTIFICAT | <br>Industrie Service   |  |
|  | <b>CONFORMITY EXAMINATION<br/>CERTIFICATE</b>  |  |
|  | <b>Certificate No.:</b>  | CA 652   |
|  | <b>Certification Body:</b>   | TÜV SÜD Industrie Service GmbH<br>Gottlieb-Daimler-Str. 7<br>70794 Filderstadt - Germany |
|  | <b>Certificate Holder:</b>   | KLAUS Multiparking GmbH<br>Hermann-Krum-Str. 2<br>88319 Aitrach - Germany                |
|  | <b>Manufacturer</b>  | KLAUS Multiparking GmbH<br>Hermann-Krum-Str. 2<br>88319 Aitrach - Germany                |
|  | <b>Product:</b>  | Equipment for power driven parking<br>of motor vehicles                                  |
|  | <b>Type:</b>   | MultiBase U10 EB 2.000 / 2.600 kg<br>MultiBase U20 EB 2.000 / 2.600 kg                   |
|  | <b>Basis of examination:</b>   | - 2006/42/EC, Annex I<br>- EN 14010:2003+A1:2009   |
|  | <b>Test report:</b>  | CA 652 dated 2020-05-19  |
| <b>Outcome:</b>  | The product conforms to the requirements of the basis of examination if the requirements of the annex to this conformity examination certificate are kept. |  |
| <b>Date of Issue:</b>                                      | 2020-05-27   |  |
| <b>Valid until:</b>  | 2025-05-26   |  |
|  | <br>Achim Janocha<br>Certification Body LCC                            |  |
|  |   |  |
|  |   |  |

## Technical information

### Area of use

In general, the system is best suited for a fixed group of users. Where users change (e. g. short-term parking in office buildings or hotels), on-site modifications are required. If needed, please contact us.

### Units

Low-noise power units mounted to rubber-bonded-to metal mountings are installed. Nevertheless, we recommend separating the garage body from the residential building.

### Environmental conditions

Environmental conditions for the area of multiparking systems. Temperature range -4 to +104° F. Relative humidity 50% and a maximum outside temperature of +104° F.

If raising and lowering times are specified, they refer to an ambient temperature of +50° F and a system arranged directly next to the hydraulic unit. These times increase at lower temperatures or with longer hydraulic lines. Wind zone 3 of 0.06 psi in accordance with DIN EN 1991-1-4.

Snow load zone 3 of 1 psi in accordance with DIN EN 1991-1-3. Snow load data apply to the lowered system (see "Vehicle data", page 4)

### Seismic considerations

Local seismic conditions might require special precautionary measures such as struts. Please contact KLAUS Multiparking for seismic reports and advice.

### Condensation water

When a warm vehicle is parked, the temperature of the interior space will increase a bit despite constructive ventilation measures (see "Ventilation", page 14). If the warmed air contacts cold elements such as concrete or steel, it cools down and the moisture in the air condenses. Since warm air rises in general, this effect mainly appears on the underside of the platforms in the Multiparking system. Condensation water is an unavoidable physical phenomenon.

### Building permit documents

Multiparking systems are usually subject to approval. Please observe local regulations and ordinances in this regard.

### Care

To prevent corrosion damage, please observe our separate cleaning and care instructions, and make sure that your garage is well ventilated.

### Corrosion protection

As per "Corrosion Protection" supplement.

### Protective grille

If the permissible fall opening is exceeded, protective grilles must be installed on the systems. If traffic routes are located immediately next to or behind the systems, then the customer must provide barriers as per DIN EN ISO 13857. This applies during the construction phase as well.

### Noise protection

#### Normal noise protection:

As per DIN 4109-1 "Sound Insulation in Buildings – Part 1: Minimum Requirements," section 9:

The maximum sound pressure level in living and sleeping spaces is 30 dB (A).

User noises are not subject to the requirements.

The following actions are required to comply with this value:

- Noise protection package as per quotation/order (KLAUS Multiparking)
- Sound reduction index of the structure at least  $R'w = 57$  dB (customer-provided performance)

#### Increased noise protection (separate agreement):

As per DIN 4109-5 "Sound Insulation in Buildings – Part 5: Increased Requirements," section 8:

Maximum sound pressure level in living and sleeping spaces 25 dB (A).

User noises are not subject to the requirements.

The following actions are required to comply with this value:

- Noise protection package as per quotation/order (KLAUS Multiparking)
- Sound reduction index of the structure at least  $R'w = 62$  dB (customer-provided performance)

#### Note:

User noises are noises that can be influenced individually by the user of our multiparking systems. This includes, e.g., driving onto the platform, slamming vehicle doors, engine noises and breaking noises.

## Performance specification

### Description

Multiparking system for independent parking of 1 vehicle (single platform - SP), one on top of the other. The top platform can be used as a parking space under certain conditions.

Dimensions as per the underlying pit, width and height dimensions. Access to the parking spaces horizontally (installation tolerance  $\pm 1\%$ ).

The special arrangement of the lifting and bearing structure allows doors to be opened without restrictions.

A vehicle positioning aid is mounted on one side of each parking space (must be adjusted as per operating instructions).

Control via an operating element with key blocking via common key.

Brief instruction at each operating point.

### Multiparking system consisting of:

- 2 telescopic lifting columns at the rear with hydraulic cylinder (secured to the floor)
- 2 telescopic lifting columns at the front (secured to the floor)
- 1 upper platform/cover (for floor covering provided by the customer, e.g. sand bed/stone covering). Maximum weight of the covering provided by the customer: 0.35 lbs/in<sup>2</sup>. Alternative version with platform profiles from KLAUS Multiparking – surcharge applies.
- 1 lower platform
- 1 mechanical synchronization system (for synchronized operation of the hydraulic cylinders during lifting and lowering)
- 2 hydraulic cylinders
- Dowels, bolts, fasteners, pins, etc.
- The platforms are end-to-end accessible for parking!

### Upper platform comprising:

- Trough for covering to be provided by the customer; alternatively platform profiles from KLAUS Multiparking
- Cover sheets
- Side beams
- Crossbeams
- Bolts, nuts, washers, etc.

### Lower platform comprising:

- Platform profiles
- Adjustable positioning aid
- Chamfered access plates
- Side beams
- Crossbeams
- Bolts, nuts, washers, spacer tubes, etc.

### Hydraulic system consisting of:

- Hydraulic cylinders
- Solenoid valves
- Hydraulic lines
- Threaded connections
- High-pressure hoses
- Fasteners

### Electrical system consisting of:

- Operating element (emergency-stop, lock, 1 common key per parking space)
- Switch cabinet with lockable master switch

### Hydraulic unit consisting of:

- Hydraulic unit (low-noise, mounted on a console with rubber-bonded-to-metal mountings)
- Hydraulic oil tank
- Oil fill
- Internal gear pump
- Pump carrier
- Coupling
- Three-phase motor
- Contactor, motor protection switch and control fuse
- Test pressure gage
- Pressure relief valve
- Hydraulic hoses (damping of noise transmission to the hydraulic pipes)

## Performances provided by customer

### Barriers

Any barriers required to secure the parking system pit due to traffic routes located immediately in front of, next to or behind the systems as per DIN EN ISO 13857. This applies during the construction phase as well. Protective grilles on the systems, where required, are available for a surcharge.

### Parking space numbering

Any parking space numbering required.

### Technical building systems

Any required lighting, ventilation, fire extinguishing systems and fire alarm systems, as well as clarification and fulfillment of the associated legal requirements.

### Lighting

The customer must observe local regulations regarding the lighting of parking spaces and roadways. In accordance with DIN EN 12464-1 "Light and Lighting – Lighting of Work Places – Part 1: Indoor Work Places" an illuminance of at least 200 lx is recommended for the parking spaces and operating area of the system or of at least 50 lx for the maintenance shaft.

### Drainage

Functional drainage of the pit must be provided by means of a floor drain in the center area that is connected to the sewer system or a pump sump. The water must be drained away by a pump provided by the customer. A slope from the corners of the pit/supporting surface of the lifting columns to the floor drain/pump sump is required. As an environmental protection measure, we recommend that the pit floor be painted. Oil or gasoline separators must be appropriately taken into account as per local regulations when the drain is attached to the sewer system. To drain large quantities of water from the yard area, the customer must install a water collection channel around the outside of the pit.

### Warning markings

As per DIN EN 14010, the customer must apply a 4" wide gold and black marking as per DIN ISO 3864 at the edge of the pit in the entry area to mark the danger area.

### Wall openings

Any required wall openings as per sectional drawings (see "Width dimensions", page 5).

#### Supply cable to the master switch – foundation ground

The customer must provide the supply cable to the master switch during assembly. Our fitter can check functionality on site together with the electronics technician. If this is not possible during assembly due to reasons for which the customer is responsible, then the customer must contract an electronics technician.

The customer must ground the steel structure using the foundation ground connection (max. ground distance 393.8") and equipotential bonding as per DIN EN 60204.

#### Operating element

The customer must provide an empty conduit (see "Electrical installation", page 10) from the pit floor to the operating element. The position of the operating element must be determined on a project-by-project basis (operating stands, house wall, etc.).

#### Installation

In general, the customer must provide a crane to aid installation of the telescopic lifting columns. Hook height min. 157.5" above entrance level; crane load approx. 1,540 lbs.

#### Maintenance shaft

A separated maintenance shaft with shaft cover, shaft ladder and access to the pit must be provided by the customer. A common maintenance shaft may be sufficient for series systems, depending on the project.

#### Ventilation

To ensure a continuous exchange of air, reduce air humidity, prevent condensation and reduce vehicle moisture (from rain, snow, ice, etc.), we recommend that the customer provide a ventilation system in conjunction with an HVAC engineer. This will help to minimize the risk of corrosion and resulting faults.

#### Covering on the upper platform

Covering on the upper platform (maximum weight of covering to be provided by the customer 0.35 lbs/in<sup>2</sup>) in accordance with the sectional drawing (see "Detail of building configuration - pit floor", page 7). This includes the proper sealing of the trough (for example structure see "Detail of building design – trough seal", page 8).

### Right to technical changes reserved.

In carrying out its performances in the course of technical progress, KLAUS Multiparking is free to use new or different technologies, systems, processes or standards than those initially quoted, provided this does not result in any disadvantages for the customer.

Manufacturer:

**KLAUS Multiparking GmbH**

Hermann-Krum-Straße 2  
D-88319 Aitrach

Phone: +49 (0) 7565 508-0

info@multiparking.com

**www.multiparking.com**

Sales office:

**KLAUS Multiparking America Inc.**

Fon: +1 848 900 1074  
america@multiparking.com

**www.multiparkingusa.com**

